

K-DRIVE

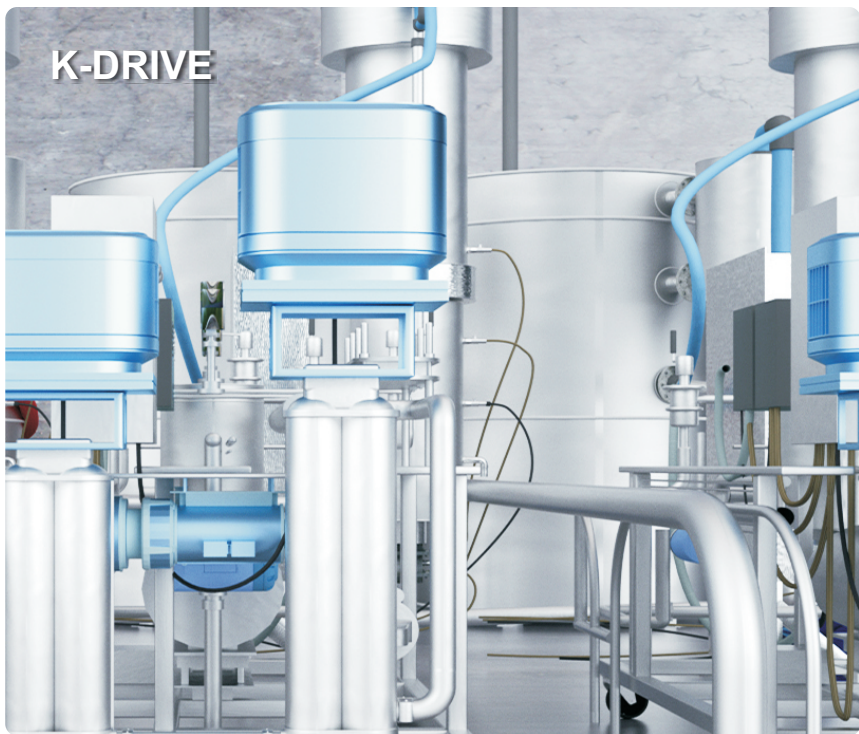

Universal vector frequency converter

KD600M Series

User Manual



<http://www.keasyautomation.com>

Preface

K-DRIVE is a professional enterprise engaged in the research and development, production, and sales of industrial automation control related products. It is positioned to serve high-end equipment manufacturers, based on industrial automation control technology with independent intellectual property rights. Its main business model is to quickly provide personalized solutions for customers, and it is continuously committed to promoting industrial upgrading with leading technology, quickly providing customers with more intelligent and accurate solutions More cutting-edge comprehensive products and solutions.

K-DRIVE has core technology platforms such as crane drive control, high-performance vector, servo drive, and permanent magnet synchronous motor drive. The product includes universal frequency converters, four quadrant frequency converters, energy feedback units, industry drive control integrated machines, servo drives, servo controllers, and other products. The product is widely used in metallurgy, mining, cement, petroleum, municipal engineering, machine tools, rubber and plastic, logistics, HVAC, construction machinery and other fields. At the same time, the product is sold in 17 countries including Russia, India, Brazil, and Vietnam.

ATTENTIONS

- Please power off when wiring.
- Electronic components inside AC drive are especially sensitive to static electricity, do not put anything into internal of AC drive. And do not touch main circuit board.
- After power cut, if indicator is still lamp, it still have high voltage in AC drive. It is very dangerous, please do not touch internal circuit and components.
- Please ensure the grounding terminals of AC drive is grounded correctly.
- Never connect input power supply with output terminal U,V,W of AC drive.

Connection to peripheral devices:

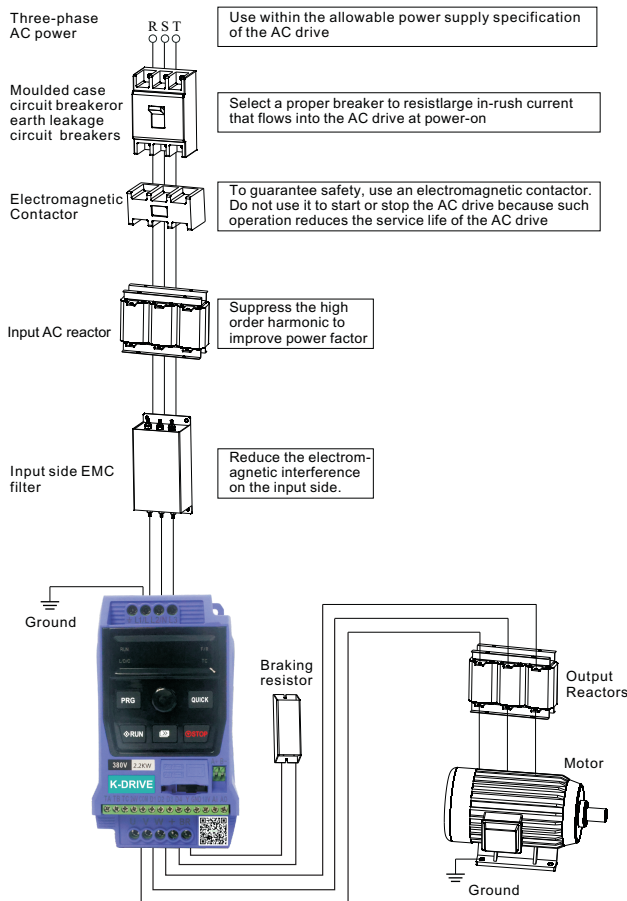

Do not install capacitors or surge suppressors on the output side of the frequency converter, as this may cause faults in the frequency converter or damage to the capacitors and surge suppressors. The input/output (main circuit) of the frequency converter contains harmonic components, which may interfere with the communication equipment of the frequency converter accessories. Therefore, install anti-interference filters to minimize interference.

Contents

Chapter 1 Safety and Attentions

| | |
|-----------------------------|---|
| 1.1 Safety Matters..... | 6 |
| 1.2 Use Considerations..... | 9 |

Chapter 2 Product Brief Introduction

| | |
|---|----|
| 2.1 Position and content of nameplate..... | 12 |
| 2.2 Naming rules..... | 12 |
| 2.3 Up in and down out models and technical data..... | 13 |
| 2.4 Technical Features..... | 14 |
| 2.5 Product Appearance..... | 17 |
| 2.6 Appearance and installation dimensions..... | 18 |
| 2.7 External keyboard with tray installation dimension drawing..... | 19 |
| 2.8 Optional accessories..... | 19 |

Chapter 3 installation

| | |
|--|----|
| 3.1 Mechanical installation..... | 22 |
| 3.2 Electrical Installation..... | 24 |
| 3.3 Basic wiring diagram..... | 26 |
| 3.4 Main circuit terminals and connection..... | 27 |
| 3.5 Control circuit terminal and wiring..... | 28 |

Chapter 4 Operation and Display

| | |
|--|----|
| 4.1 Keypad description..... | 32 |
| 4.2 Organization of Inverter Function Codes..... | 34 |
| 4.3 Function code viewing and modification method description..... | 34 |

Chapter 5 Synchronous Motor Open Loop Vector (SVC) Commissioning Instructions

| | |
|--|----|
| 5.1 Set the synchronization type, control method and motor parameters..... | 38 |
| 5.2 Parameter identification..... | 38 |
| 5.3 No-load test run..... | 38 |
| 5.4 Quick start test run..... | 39 |
| 5.5 Load and run..... | 39 |

Chapter 6 Troubleshooting and Countermeasures

| | |
|--|----|
| 6.1 Fault alarm and countermeasures..... | 42 |
| 6.2 Common faults and their solutions..... | 47 |
| 6.3 Common faults of synchronous motors and their solutions..... | 49 |

Chapter 7 Modbus communication protocol

| | |
|---|----|
| 7.1 Communication frame structure..... | 52 |
| 7.2 Address Definition of Communication Parameters..... | 54 |

Chapter 8 Function & Parameter Table

| | |
|---------------------------|----|
| 8.1 Functional group..... | 60 |
|---------------------------|----|

Warranty

Warranty Card

Certificate of quality





Chapter 1

Safety and Attentions





| | |
|-----------------------------|---|
| 1.1 Safety Matters..... | 6 |
| 1.2 Use Considerations..... | 9 |





Users are requested to read this chapter carefully when installing, commissioning and repairing this product and perform the operation according to safety precautions as set forth in this chapter without fail. Our company will bear no responsibility for any injury and loss as a result of any violation operation.







Safety signs in this manual

| | |
|--|--|
|  DANGER | Dangers caused by operations beyond requirements may lead to serious injury, and even death. |
|  CAUTION | Dangers caused by operations beyond requirements may lead to moderate damages or minor injuries, as well as equipment damages. |

1.1 Safety Matters

| Use Stage | Safety Grade | Precautions |
|---------------------|---|--|
| Before Installation |  DANGER | <ul style="list-style-type: none"> ◇ Do not install the product if the package is with water, or component is missing or broken; ◇ Do not install the product if the label on the package is not identical to that on the inverter. |
| |  CAUTION | <ul style="list-style-type: none"> ◇ Be careful of carrying or transportation. Risk of devices damage; ◇ Do not use damaged product or the inverters missing component. Risk of injury; ◇ Do not touch the parts of control system with bare hands. Risk of ESD hazard. |
| Installation |  DANGER | <ul style="list-style-type: none"> ◇ Installation base shall be metal or other non-flammable material. Risk of fire; ◇ Do not install inverter in an environment containing explosive gases, otherwise there is danger of explosion; ◇ Do not unscrew the fixing bolts, especially the bolts with red mark. |
| |  DANGER | <ul style="list-style-type: none"> ◇ Do not leave cable strips or screws in the inverter. Risk of inverter damage; ◇ Install the product at the place with less vibration and no direct sunlight; |

| Use Stage | Safety Grade | Precautions |
|-----------------|---|--|
| Installation |  DANGER | <ul style="list-style-type: none"> ◇ Consider the installation space for cooling purpose when two or more inverters are placed in the same cabinet. |
| Wiring |  DANGER | <ul style="list-style-type: none"> ◇ Wiring must be performed by authorized and qualified personnel. Risk of danger; ◇ Circuit-breaker should be installed between inverter and the mains. Risk of fire; ◇ Make sure the input power supply has been completely disconnected before wiring. Failure to comply may result in personnel injury and/or equipment damage; ◇ Since overall leakage current of this equipment may be bigger than 3.5mA, for safety's sake, this equipment and its associated motor must be well grounded so as to avoid risk of electric shock; ◇ Never connect the power cables to the output terminals (U,V,W) of the AC drive. Pay attention to the marks of the wiring terminals and ensure correct wiring. Failure to comply will result in damage to the AC drive; ◇ Install braking resistors at terminals (P+)and (P- or PB) only. Failure to comply may result in equipment damage. |
| |  CAUTION | <ul style="list-style-type: none"> ◇ Since all adjustable frequency AC drives from Our company have been subjected to hi-pot test before delivery, users are prohibited from implementing such a test on this equipment. Failure to comply may result in equipment damage. ◇ Signal wires should to the best of the possibility be away from main power lines. If this cannot be ensured, vertical cross-arrangement shall be implemented, otherwise interference noise to control signal may occur. ◇ If motor cables are longer than 100m, it is recommended output AC reactor be used. Failure to comply may result in faults. |
| Before Power-on |  DANGER | <ul style="list-style-type: none"> ◇ Inverter shall be power-on only after the front cover is assembled. Risk of electrical hazard. |
| |  CAUTION | <ul style="list-style-type: none"> ◇ Verify that the input voltage is identical to the rated voltage of product, correct wiring of input terminals R, |

| Use Stage | Safety Grade | Precautions |
|------------------|--|---|
| Before Power-on |  CAUTION | S, T or L1, L2 and output terminals U, V, and W, wiring of inverter and its peripheral circuits, and all wires should be in good connection. Risk of inverter damage. |
| After Power-on |  DANGER | <ul style="list-style-type: none"> ◇ Do not open the cover after power. Risk of electrical hazard; ◇ Do not touches any input/output terminals of inverter with bare hands. Risk of electrical hazard. |
| |  CAUTION | <ul style="list-style-type: none"> ◇ If auto tuning is required, be careful of personal injury when motor is running. Risk of accident; ◇ Do not change the defaults of parameters. Risk of devices damage. |
| During Operation |  DANGER | <ul style="list-style-type: none"> ◇ Non-professionals shall not detect signals during operation. Risk of personal injury or device damage; ◇ Do not touch the fan or the discharging resistor to check the temperature. Failure to comply will result in personal burnt. |
| |  CAUTION | <ul style="list-style-type: none"> ◇ Prevent any foreign items from being left in the devices during operation. Risk of device damage; ◇ Do not control start/stop of inverter by ON/OFF of contactor. Risk of device damage. |
| Maintenance |  DANGER | <ul style="list-style-type: none"> ◇ Please do not make repair and maintenance over equipment in a charged state, or it will give rise to electric shock hazard! ◇ AC drive can be put into maintenance and repair only you confirm the AC drive charge light out, or the remaining electric charge of capacitance will cause damages to people! ◇ Any people who are not trained professionally cannot make repair and maintenance, or it will cause personal injuries or equipment troubles! |

1.2 Use Considerations

1.2.1 Motor Insulation Inspection

When the motor is used for the first time or when the motor is reused after being kept, or when periodical inspection is performed, insulation inspection shall be conducted with motor so as to avoid damaging the inverter because of the insulation failure of the motor windings. The motor wires must be disconnected from the inverter during the insulation inspection. It is recommended to use the 500V mega meter, and the insulating resistance measured shall be $5M\Omega$ at least.

1.2.2 Motor Thermal Protection

If the motor rating does not match that of the inverter, especially when the rated power of the inverter is higher than that of the motor, adjust motor protection parameters in the inverter or install thermal relay to protect motor.

1.2.3 Operating with the Frequency Higher than Grid Power Frequency

Output frequency of is 0.00Hz~500Hz. If product is required to operate above 50.00Hz, please take the endurance of mechanical devices into consideration.

1.2.4 Mechanical Vibrations

Inverter may encounter mechanical resonance point of the load device at certain output frequencies which can be avoided by setting the skip frequency parameters of the inverter.

1.2.5 Motor Heat and Noise

Since output voltage of inverter is PWM wave and contains a certain amount of harmonics, so that the temperature, noise and vibration of the motor will be higher than those when the inverter runs at grid power frequency.

1.2.6 Voltage-sensitive device or capacitor on output side of the AC drive

Do not install the capacitor for improving power factor or lightning protection voltage-sensitive resistor on the output side of the AC drive because the output of the AC drive is PWM wave. Otherwise, the AC drive may suffer transient overcurrent or even be damaged.

1.2.7 Contactor at the I/O terminal of the AC drive

When a contactor is installed between the input side of the AC drive and the power supply, the AC drive must not be started or stopped by switching the contactor on or off. If the AC drive has to be operated by the contactor, ensure that the time interval between switching is at least one hour since frequent charge and discharge will shorten the service life of the capacitor inside the AC drive;

When a contactor is installed between the output side of the AC drive and the motor, do not turn off the contactor when the AC drive is active. Otherwise, modules inside the AC drive may be damaged.

1.2.8 Applied with the Rated Voltage

Apply product with the rated voltage. Failure to comply will damage inverter. If required, take a transformer to boost or step-down voltage.

1.2.9 Do Not Apply a 3-Phase Input Inverter to 2-Phase Input Applications

Do not apply a 3-phase input FR inverter to 2-phase input applications. Otherwise, it will result in faults or damage inverter.

1.2.10 Lightning Protection

The product has integrated lightning over-current protection device which has certain self-protection capacity against the lightning. Additional protection devices have to be installed between inverter and power supply in the area where lightning occurs frequently.

1.2.11 Altitude De-rating

In places where the altitude is above 1000 m and the cooling effect reduces due to thin air, it is necessary to de-rate the AC drive. Contact Our company for technical support.

1.2.12 Adaptable Motor

Standard adaptive motor is quadrupole squirrel- cage asynchronous induction motor. If it is not above- mentioned motor, please select AC drive upon rated current of moter. If you need to drive permanent magnet synchronous motor, please consult our company;

The cooling fan of non variable frequency motor and rotor spindle are coaxially connected. While despinning, the fan cooling effect also declines at the same time.Hence, for overheated occasion of moter, you shall install strong exhaust fan or change variable frequency motor;

AC drives have built- in adaptive motor standard parameters. It is necessary to make motor parameter identification or amend default values to accord with actual values, or it will influence operation effects and protective values;

As short circuit existing inside cable or motor will cause inverter alarming, enen explosion. Therefore, please make insulation short- circuit test of initial installed motor and cable first. And the test also is necessary in routine maintenance.



Chapter 2

Product Brief Introduction

| | |
|---|----|
| 2.1 Position and content of nameplate..... | 12 |
| 2.2 Naming rules..... | 12 |
| 2.3 Up in and down out models and technical data..... | 13 |
| 2.4 Technical Features..... | 14 |
| 2.5 Product Appearance..... | 17 |
| 2.6 Appearance and installation dimensions..... | 18 |
| 2.7 External keyboard with tray installation dimension drawing..... | 19 |
| 2.8 Optional accessories..... | 19 |

2.1 Position and content of nameplate



2.2 Naming rules

KD600M - 2 S - 2.2 G / 4.0 P

①
②
③
④
⑤
④
⑤

| Code | No. | Content |
|------------------------|-----|---|
| Product series | ① | KD600M series |
| Voltage level | ② | 2 : 220V 4 : 380V |
| Voltage Classification | ③ | S : Single-phase T : Three phase |
| Adapted motor power | ④ | 0.4KW~5.5KW |
| Application | ⑤ | G: Universal type P: Fan and water pump type |

2.3 Up in and down out models and technical data

| Drive model (Top in and bottom out models) | 1-phase rated input current(A) | 3-phase rated input current(A) | Applicable motor (kW) |
|---|-----------------------------------|-----------------------------------|--------------------------|
| Single phase 220V range: -15%~+20% | | | |
| KD600M-2S-0.4G | 5.4 | 2.3 | 0.4 |
| KD600M-2S-0.7G | 8.2 | 4 | 0.75 |
| KD600M-2S-1.5G | 14 | 7 | 1.5 |
| KD600M-2S-2.2G | 23 | 9.6 | 2.2 |
| KD600M-2S-4.0G | 40 | 17 | 4.0 |
| Three phase 220V range: -15%~+20% | | | |
| KD600M-2T-0.4G | 2.7 | 2.3 | 0.4 |
| KD600M-2T-0.7G | 4.2 | 4 | 0.75 |
| KD600M-2T-1.5G | 7.7 | 7 | 1.5 |
| KD600M-2T-2.2G | 12 | 9.6 | 2.2 |
| KD600M-2T-4.0G | 19 | 17 | 4.0 |
| Three phase 380V range: -15%~+20% | | | |
| KD600M-4T-0.7G/1.5P | 3.4/5.0 | 2.1/3.8 | 0.75/1.5 |
| KD600M-4T-1.5G/2.2P | 5.0/5.8 | 3.8/5.1 | 1.5/2.2 |
| KD600M-4T-2.2G/3.7P | 5.8/10.5 | 5.1/9.0 | 2.2/4.0 |
| KD600M-4T-4.0G/4.0P | 10.5/14.6 | 9.0/13.0 | 4.0/5.5 |
| KD600M-4T-5.5G/7.5P | 14.6/20.5 | 13.0/17.0 | 5.5/7.5 |
| KD600M-4T-7.5G/11P | 20.5/26.0 | 17.0/25.0 | 7.5/11.0 |
| KD600M-4T-11G/15P | 26.0/35.0 | 25.0/32.0 | 11.0/15.0 |
| KD600M-4T-15G/18P | 35.0/38.5 | 32.0/37.0 | 15.0/18.0 |

2.4 Technical Features

| | Technical Features | Description |
|---------------------|--|---|
| Control performance | Highest frequency | Vector control: 0~600Hz VF control: 0~1200Hz |
| | Carrier frequency | 1K~15kHz; the carrier frequency can be adjusted automatically according to the load characteristics. |
| | Input frequency resolution | Digital setting: 0.01Hz Analog setting: maximum frequency \times 0.1% |
| | Control mode | Open loop vector control (SVC), V/F control |
| | Starting torque | G type machine: 0.5Hz/180% (open loop vector control) P type machine: 0.5Hz/120% (open loop vector control) |
| | Speed range | 1: 200 (open loop vector control) |
| | Steady speed accuracy (speed control accuracy) | Open-loop vector control: $\leq \pm 0.5\%$ (rated synchronous speed) |
| | Speed control stability | Open-loop vector control: $\leq \pm 0.3\%$ (rated synchronous speed) |
| | Torque Response | $\leq 40\text{ms}$ (open loop vector control) |
| | Overload capability | Model G: 150% rated current for 60 seconds; 180% rated current for 5 seconds P-type machine: 120% rated current for 60 seconds; 150% rated current for 5 seconds |
| | Torque boost | Automatic torque boost; manual torque boost 0.1%~30.0% |
| | V/F curve | Three ways: linear type; multi-point type; square type V/F curve |
| | Acceleration and deceleration curve | Linear or S-curve acceleration and deceleration mode; four kinds of acceleration and deceleration time; acceleration and deceleration time range 0.0s 3000.0s |
| | DC brake | DC braking frequency: 0.0Hz~maximum frequency, braking time: 0.0~36.0 seconds, braking action current value: 0.0%~100.0% |
| | Jogging Control | Jog frequency range: 0.00Hz~50.00Hz; Jog acceleration and deceleration time 0.0s~3000.0s |
| | Simple PLC & multi step speed operation | Built-in PLC or control terminal, 16 steps speed can be set |
| | Built-in PID | Process control closed-loop control system can be easily realized |

| | Technical Features | Description |
|---------------------|--|---|
| Control performance | Automatic voltage regulation(AVR) | When the grid voltage changes, it can automatically keep the output voltage constant |
| | Torque Limiting and Control | "Excavator" feature, automatically limit the torque during operation to prevent frequent overcurrent tripping; closed-loop vector mode can realize torque control |
| Personalization | Power-on peripheral device safety self-check | It can realize safety detection of peripheral equipment such as grounding, short circuit, etc. |
| | Common DC bus function | It can realize the function of sharing the DC bus of multiple inverters |
| | JOG key | Programmable keys: forward and reverse running/jog running function selection |
| | Textile swing frequency control | Various triangular wave frequency control functions |
| | Fast current limiting function | The built-in fast current limiting algorithm reduces the probability of overcurrent reported by the inverter and improves the anti-interference ability of the whole machine |
| | Timing control | Timing control function: Set time range 0h~65535h |
| | Standardized keyboard extension cables | Customers can use standard network cables to extend the keyboard. |
| Run | Run command channel | Three channels: operation panel given, control terminal given, serial communication port given. Switchable in a variety of ways |
| | Frequency source | There are 10 kinds of frequency sources: digital given, analog voltage given, analog current given, pulse given, serial port given. Switchable in a variety of ways |
| | Auxiliary frequency source | 10 auxiliary frequency sources. Auxiliary frequency fine-tuning and frequency synthesis can be flexibly realized |
| | Input terminal | Standard configuration includes four digital input terminals, with up to five digital input terminals (AI1 can be used as a DI terminal). The NPN input method has one analog input terminal, and AI1 can be used for voltage or current input. |
| | Output terminal | One high-speed pulse output terminal and one relay output terminal; An analog output terminal, available in 0/4mA-20mA or 0/2V-10V, capable of outputting physical quantities such as set frequency, output frequency, and speed |

| Technical Features | | Description |
|--------------------------------|--|--|
| Display and keyboard operation | LED Display | Display parameters |
| | LCD Display | Optional, Chinese/English/Russian prompts for operation content |
| | LCD parameter copy | The use of LED and LCD enables rapid replication of parameters |
| | Key lock and function selection | Part or all of the keys can be locked, and the scope of action of some keys can be defined to prevent misoperation |
| Protection and Options | Protective function | Power-on motor short-circuit detection, input and output phase loss protection, overcurrent protection, overvoltage protection, undervoltage protection, overheating protection, overload protection, etc. |
| | Optional accessories | LCD operation panel, brake assembly, etc. |
| State | Place of use | Indoor, no direct sunlight, no dust, corrosive gas, flammable gas, oil mist, water vapor, dripping water or salt, etc. |
| | Altitude | Below 1000 meters |
| | Ambient temperature | -10°C ~ +50°C (Ambient temperature is 40°C ~ 50°C, please use with derating) |
| | Humidity | Less than 95%RH, no condensation |
| | Vibration | Less than 5.9m/s ² (0.6g) |
| | Storage temperature | -20°C ~ +60°C |
| | Pollution level | 2 |
| Product Standards | Product implementation of safety standards | IEC61800-5-1:2007 |
| | Products comply with EMC standards | IEC61800-3:2005 |

2.5 Product Appearance



| No. | Name | Description |
|-----|----------------------|--|
| ① | Keypad | LED display operation panel |
| ② | Power label | Voltage level and power identification |
| ③ | Functional terminals | Multifunctional wiring terminals |
| ④ | Output terminal | External motor output terminal, optional external brake resistor terminal |
| ⑤ | Input terminals | External power input wiring terminals |
| ⑥ | Installation holes | Installation fixing hole position |
| ⑦ | Functional terminals | 485 communication interface terminal |
| ⑧ | Selection switch | AI and AO voltage/current selection switches, optional external operation display keyboard RJ45 port |
| ⑨ | Nameplate | Product Information |
| ⑩ | QR code | Official account, data download |

2.6 Appearance and installation dimensions

| Drive model (Top in and bottom out models) | Adapter motor (KW) | Installation size(mm) | | Dimensions (mm) | | | Aperture d |
|--|--------------------------|--------------------------|-----|--------------------|-----|-----|-------------------|
| | | A | B | H | W | D | |
| Single phase 220V range: -15%~+20% | | | | | | | |
| KD600M-2S-0.4G | 0.4 | 66 | 136 | 149 | 83 | 111 | 5 |
| KD600M-2S-0.7G | 0.75 | | | | | | |
| KD600M-2S-1.5G | 1.5 | | | | | | |
| KD600M-2S-2.2G | 2.2 | 80 | 157 | 170 | 98 | 124 | 5 |
| KD600M-2S-4.0G | 4.0 | | | | | | |
| Three phase 220V range: -15%~+20% | | | | | | | |
| KD600M-2T-0.4G | 0.4 | 66 | 136 | 149 | 83 | 111 | 5 |
| KD600M-2T-0.7G | 0.75 | | | | | | |
| KD600M-2T-1.5G | 1.5 | | | | | | |
| KD600M-2T-2.2G | 2.2 | 80 | 157 | 170 | 98 | 124 | 5 |
| KD600M-2T-4.0G | 4.0 | | | | | | |
| Three phase 380V range: -15%~+20% | | | | | | | |
| KD600M-4T-0.7G/1.5P | 0.75 | 66 | 136 | 149 | 83 | 111 | 5 |
| KD600M-4T-1.5G/2.2P | 1.5 | | | | | | |
| KD600M-4T-2.2G/3.7P | 2.2 | | | | | | |
| KD600M-4T-4.0G/4.0P | 4.0 | 80 | 157 | 170 | 98 | 124 | 5 |
| KD600M-4T-5.5G/7.5P | 5.5 | | | | | | |
| KD600M-4T-7.5G/11P | 7.5 | | | | | | |
| KD600M-4T-11G/15P | 11 | 112 | 200 | 228 | 135 | 160 | 5 |
| KD600M-4T-15G/18P | 15 | | | | | | |

2.7 External keyboard with tray installation dimension drawing

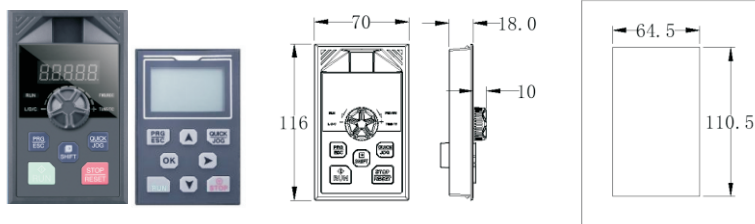

The optional external LED keyboard and LCD keyboard have the same size, and the tray opening size is 64.5mm in length and 110.5mm in width.

2.8 Optional accessories

The detailed functions and usage instructions of the optional accessories can be found in the relevant optional accessory instructions. If the above optional accessories are required, please specify them when placing an order.

| Name | Model | Function | Remarks |
|-------------------------------|--------------------------------------|--|--|
| Built-in braking unit | "B" after the product model number | For dynamic braking | Built-in braking unit is standard |
| | "(B)" after the product model number | For dynamic braking | Built-in braking unit is optional |
| External LED operation panel | KD600-LED | External LED display and operation keyboard | KD series general RJ45 interface |
| External LCD operation panel | KD600E-LCD | External LCD display and operating keyboard | KD series general RJ45 interface |
| External LED2 operation panel | KD600-LED2 | External LED display and pure key keyboard | KD series general RJ45 interface |
| Keyboard gusset | KD600KB | When running without a keyboard or when the keyboard is externally drawn, using this keyboard gusset will have a good protective and aesthetic effect. | Optional |
| Extension cable | KD-CAB | Standard 8-core network cable, can be connected with KD600-LED, KD600-LCD, KD600-LED2 | Available in 4 sizes: 1m, 3m, 5m and 10m |



Chapter 3

Installation

| | |
|--|----|
| 3.1 Mechanical installation..... | 22 |
| 3.2 Electrical Installation..... | 24 |
| 3.3 Basic wiring diagram..... | 26 |
| 3.4 Main circuit terminals and connection..... | 27 |
| 3.5 Control circuit terminal and wiring..... | 28 |

3.1 Mechanical Installation

3.1.1 Installation Environment

- Environment temperature: Surrounding environment temperature has a great impact on lifetime of AC drive, and the operation environment temperature of AC drive shall not exceed allowable temperature range ($-10^{\circ}\text{C} \sim 40^{\circ}\text{C}$).
- While AC drive is installed on the surface of inflaming retardants, and enough space around is necessary for heat dissipation. When AC drive works, it will produce plenty of heats. And make vertical installation onto supporting holder with screw.
- Please install it in some places that are not easy to vibrate. And the vibration shall not be larger than 0.6G. Especially pay attention to keep away from punching machine and other equipments.
- Avoid to be installed where there are direct sunlights, moist surroundings and water drops.
- Avoid to be installed where there are corrosivity, inflammability and explosive gas.
- Avoid to be installed where there are oil contamination, dirts and metal dusts.

3.1.2 Reminder of installation site

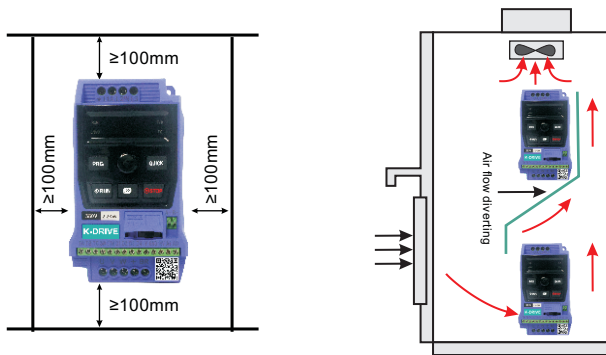

Single installation diagram

Multiple Installation Diagram

Figure 3-1 Installation diagram of AC drive

3.1.3 The installation of the model needs to pay attention to the problem of heat dissipation. So please note the following:

- Please install the inverter vertically so that the heat can be dissipated upwards. But not upside down. If there are many inverters in the cabinet, it is better to install them side by side. In the occasions that need to be installed up and down, please refer to Figure 3-1 to install the heat insulation deflector.
- The installation space is as shown in Figure 3-1 to ensure the cooling space of the inverter. However, please consider the heat dissipation of other components in the cabinet when arranging.
- The mounting bracket must be made of flame retardant material.
- For applications with metal dust, it is recommended to install the radiator outside the cabinet. At this time, the space in the fully sealed cabinet should be as large as possible.

3.1.4 Mechanical installation methods and steps

Plastic structure through wall installation

Installation instructions:

- Remove the inverter base plate;
- Insert the box into the cabinet with installed dimensions and holes, and secure it with M4x12 screws and M4 nuts;
- Replace the bottom plate with the frequency converter;

The hole size for wall mounted installation is detailed in Table 2-5.

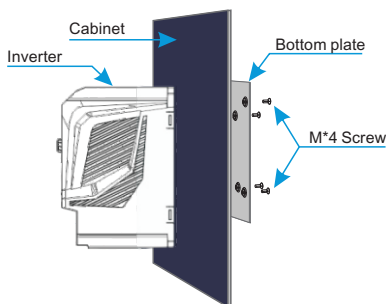

3.2 Electrical Installation

3.2.1 Guidelines for selecting peripheral electrical components

The description of the selection guide for peripheral electrical components of the frequency converter in this section mainly takes the G-type machine as an example. If you are using it as a P-type machine, please refer to the selection of electrical components in the same power range of the G-type machine.

| Models | MCCB (A) | Contactor (A) | Cable of Input Side Main Circuit (mm ²) | Cable of Output Side Main Circuit (mm ²) | Cable of Control Circuit (mm ²) |
|---|----------|---------------|---|--|---|
| Single phase 220V range: -15%~+20% | | | | | |
| KD600M-2S-0.4G | 16 | 10 | 2.5 | 2.5 | 1.0 |
| KD600M-2S-0.7G | 16 | 10 | 2.5 | 2.5 | 1.0 |
| KD600M-2S-1.5G | 20 | 16 | 4.0 | 2.5 | 1.0 |
| KD600M-2S-2.2G | 32 | 20 | 6.0 | 4.0 | 1.0 |
| Three phase 220V range: -15%~+20% | | | | | |
| KD600M-2T-0.4G | 10 | 10 | 2.5 | 2.5 | 1.0 |
| KD600M-2T-0.7G | 16 | 10 | 2.5 | 2.5 | 1.0 |
| KD600M-2T-1.5G | 16 | 10 | 2.5 | 2.5 | 1.0 |
| KD600M-2T-2.2G | 25 | 16 | 4.0 | 4.0 | 1.0 |
| Three phase 380V range: -15%~+20% | | | | | |
| KD600M-4T-0.7G/1.5P | 10 | 10 | 2.5 | 2.5 | 1.0 |
| KD600M-4T-1.5G/2.2P | 16 | 10 | 2.5 | 2.5 | 1.0 |
| KD600M-4T-2.2G/3.7P | 16 | 10 | 2.5 | 2.5 | 1.0 |
| KD600M-4T-4.0G/4.0P | 25 | 16 | 4.0 | 4.0 | 1.0 |
| KD600M-4T-5.5G/7.5P | 32 | 25 | 4.0 | 4.0 | 1.0 |

3.2.2 Instructions for using peripheral electrical components

| Accessory Name | Installation position | Function Description |
|-------------------|--|--|
| Air switch | Input circuit front end | Power outage during overcurrent of downstream equipment |
| Contactors | Between the air switch and the input side of the frequency converter | Power on/off operation of frequency converter. Frequent power on and off operations on the frequency converter through contactors (less than twice per minute) or direct startup operations should be avoided |
| AC input reactor | Input side of frequency converter | <ul style="list-style-type: none"> ◇ Improve the power factor on the input side; ◇ Effectively eliminating high-order harmonics on the input side to prevent damage to other equipment caused by voltage waveform distortion; ◇ Eliminate input current imbalance caused by power supply phase imbalance. |
| EMC input filter | Input side of frequency converter | <ul style="list-style-type: none"> ◇ Reduce external conduction and radiation interference of frequency converters; ◇ Reduce conducted interference from the power supply end to the frequency converter and improve the anti-interference ability of the frequency converter. |
| AC output reactor | Install near the frequency converter between the output side of the frequency converter and the motor. | <ul style="list-style-type: none"> ◇ The output side of the frequency converter generally contains a lot of high-order harmonics. When the distance between the motor and the frequency converter is far, there is a large distributed capacitance in the circuit. One of the harmonics may cause resonance in the circuit, resulting in two impacts: <ul style="list-style-type: none"> ◇ Damaging the insulation performance of the motor can damage the motor over time. ◇ Generate significant leakage current, causing frequent protection of the frequency converter. ◇ Generally, if the distance between the frequency converter and the motor exceeds 100 meters, it is recommended to install an output AC reactor. |

3.3 Basic wiring diagram

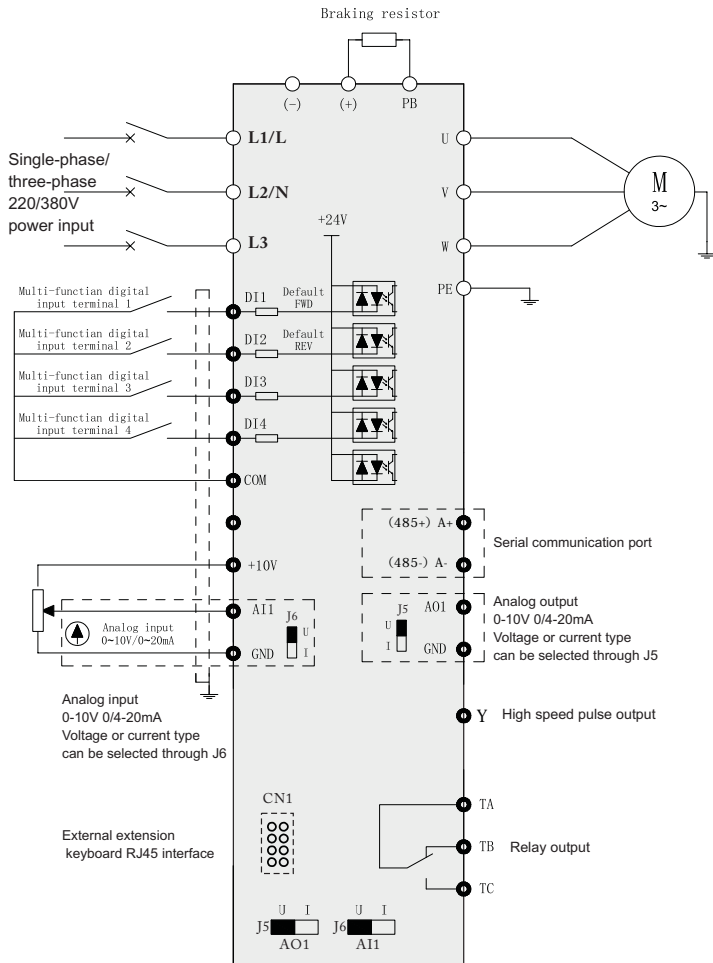



Figure 3-3 Terminal connection diagram

3.4 Main circuit terminals and connection

3.4.1 Single phase inverter main loop terminal Description:

| Terminal | Name | Function description |
|---|--------------------------------------|---|
| L, N | Single-phase power input terminal | Single-phase 220V AC power connection point |
| +, BR | Braking resistor connection terminal | Connect the braking resistor |
| U, V, W | Inverter output terminal | Connecting a three-phase motor |
|  | Ground terminal | Ground terminal |

3.4.2 Three-phase inverter main loop terminal Description:

| Terminal | Name | Function description |
|---|--------------------------------------|---|
| L1, L2, L3 | Three-phase power input terminal | AC input three-phase power connection point |
| +, BR | Braking resistor connection terminal | Connect the braking resistor |
| U, V, W | Inverter output terminal | Connecting a three-phase motor |
|  | Ground terminal | Ground terminal |

3.4.3 Wiring Precautions



DANGER

- Input power supply L, N or L1, L2, L3: The input side wiring of the frequency converter has no phase sequence requirements.
- DC bus+: Note that there is residual voltage at the terminals of the DC bus+after a power outage. Wait for the power indicator light on the drive board to turn off and confirm the power outage for 10 minutes before proceeding with wiring operations, otherwise there is a risk of electric shock.
- Brake resistor connection terminals+and BR.
- The selection of braking resistors should refer to the recommended values and the wiring distance should be less than 5m. Otherwise, it may cause damage to the frequency converter.
- Output side U, V, W of frequency converter:

**DANGER**

- Capacitors or surge absorbers should not be connected to the output side of the frequency converter, otherwise it may cause frequent protection or even damage to the frequency converter.
- When the motor cable is too long, due to the influence of distributed capacitance, it is easy to generate electrical resonance, which can cause insulation damage to the motor or generate large leakage current to protect the frequency converter from overcurrent. When the length of the motor cable is greater than 100m, an AC output reactor must be installed near the frequency converter.
- Grounding terminal PE: The terminal must be reliably grounded, and the resistance of the grounding wire must be less than 0.1Ω . Otherwise, it may cause abnormal operation or even damage to the equipment. Do not share the grounding terminal with the N terminal of the power supply neutral wire.

3.5 Control circuit terminal and wiring

3.5.1 Schematic diagram of control circuit wiring terminal



| | |
|----|----|
| A+ | B- |
|----|----|

| | | | | | | | | | | | | | |
|----|----|----|-----|-----|----|----|----|----|---|-----|-----|----|----|
| TA | TB | TC | 24V | COM | D1 | D2 | D3 | D4 | Y | GND | 10V | AI | AO |
|----|----|----|-----|-----|----|----|----|----|---|-----|-----|----|----|

3.5.2 Control terminal function description:

| Sort | Terminal | Name | Function Description |
|--------------------------|------------------------------|--------------------------------|--|
| Power supply | +10V-GND | External +10V power supply | Provide +10V power supply to the outside, the maximum output current: 10mA Generally used as working power supply of external potentiometer, potentiometer resistance range: 1~5kΩ |
| | 24V-COM | External +24V power supply | Provide +24V power supply to the outside, generally used as the working power supply of digital input and output terminals and external sensor power supply, Maximum output current: 200mA |
| Analog input | AI1-GND | Analog input terminal 1 | 1. Input voltage range: DC0~10V 2. Input impedance: 100KΩ 3. Input current range: 0 ~ 20mA |
| Digital input | DI1-COM | Digital input 1 | 1. Optocoupler isolation, NPN mode 2. Input impedance: 3.3kΩ 3. Level input voltage range: 9~30V |
| | DI2-COM | Digital input 2 | |
| | DI3-COM | Digital input 3 | |
| | DI4-COM | Digital input 4 | |
| Analog output | AO1-GND | Analog output 1 | The voltage or current output is determined by the DIP switch on the control board (refer to the bit number of the terminal wiring diagram). |
| Digital output | Y | Digital output 1 | Programmable optocoupler isolation, open collector output, maximum frequency: 50KHz. Output voltage range: 0/24VDC, output current range: 50mA |
| Communication Interface | A+,B- | Modbus communication interface | Modbus communication interface. |
| Relay output 1 | TA-TB | Normally closed terminal | Contact drive capability: AC250V, 3A, COSφ=0.4. DC30V, 1A |
| | TA-TC | Normally open terminal | |
| Keyboard extension cable | Control board RJ45 interface | External keyboard interface | External keyboard interface, can use standard network cable for external extension. |

3.5.3 Signal input terminal wiring instructions:

A. AI analog input terminal:

Because the weak analog voltage signal is particularly vulnerable to external interference, it is generally necessary to use a shielded cable, and the wiring distance is as short as possible, not more than 20m, as shown below. In some cases where the analog signal is seriously interfered with, the filter capacitor or ferrite core should be added to the analog signal source.

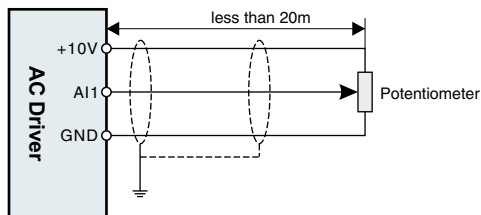

Figure 3-6 Wiring diagram of analog input terminal

B. DI digital input terminals:

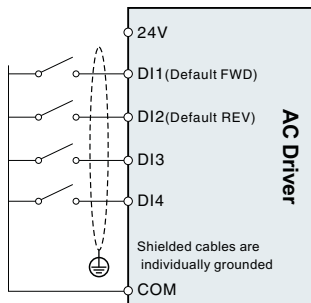

Figure 3-7 Digital input terminal NPN mode wiring diagram

Generally, it is necessary to use shielded cables, and the wiring distance is as short as possible, not more than 20 meters. When the active drive is selected, the necessary filtering measures should be taken to filter the crosstalk of the power supply. Contact control is recommended.



Chapter 4

Operation and Display

| | |
|--|----|
| 4.1 Keypad description..... | 32 |
| 4.2 Organization of Inverter Function Codes..... | 34 |
| 4.3 Function code viewing and modification method description..... | 34 |

4.1 Keypad description

4.1.1 Keypad explanation and function

Using the operation panel, you can modify the function parameters of the inverter, monitor the working status of the inverter, and control the operation of the inverter (start, stop). Its appearance and functions are shown in the following figure.



Figure 4-1 Built in LED digital display operation panel
(standard configuration, non removable)

4.1.2 Function indicator description







| Indicator sign | Name | meaning | Color |
|----------------|---------------------------------------|--|-------|
| RUN | Operating status indicator | On - the inverter is running Off - Inverter is in stop state Flashing - the inverter is in sleep state | Green |
| L/D/C | Control mode indicator | Off - Inverter is in keypad control mode On - the inverter is in terminal control mode Flashing-Inverter is in remote communication control mode | Red |
| FWD/REV | Running direction indication | Off - Forward state On - inversion state Flashing - the target frequency is opposite to the actual frequency or is in the reverse running prohibited state | Red |
| TUNE/TC | Tuning/Torque Control/Fault Indicator | On - torque control Flashing - Tuning\Fault status | Red |

4.1.3 Digital display area

5-digit LED display can display the set frequency, output frequency, various monitoring data and alarm codes. The function code is usually displayed as a decimal number. For example, the value of the P0-11 function code is displayed as "50.00", which means the decimal number "50.00". When the function code value is displayed in hexadecimal, the highest digit of the nixie tube displays "H.", indicating that the current function code value is displayed in hexadecimal. For example, the value of the P7-29 function code is displayed as "H. At this time, the value of P7-29 is the hexadecimal number "0x3f".

The user can freely set the monitoring data of stop and running status according to function code P7-29/P7-30, see function code P7-29/P7-30 for details.

4.1.4 Description of keyboard buttons

| Button | Name | Function Description |
|---|---------------------------|--|
|  | Program / Escape key | Enter or exit the first-level menu, return to the upper-level menu |
|  | Enter | Enter the menu screen step by step, set parameters to confirm |
| | Increment key (+) | Increment of data or function code |
| | Decrement key (-) | Decrement of data or function code |
|  | Shift key | In the stop display interface and the running display interface, the display parameters can be selected cyclically. For the specific display meaning, please refer to P7-29 and P7-30; when modifying the parameters, you can select the modification bit of the parameter |
|  | Run key | In keyboard operation mode, used to run operation |
|  | Stop/Reset key | In the running state, pressing this key can be used to stop the running operation; in the fault alarm state, it can be used to reset the operation. The characteristics of this key are restricted by the function code P7-27. |
|  | Jog run/Direction keys | When P7-28 is set to 0, it is the jog running button, and when P7-28 is set to 1, it is the direction button. Press this button to reverse the direction. |

4.2 Organization of Inverter Function Codes

| Function code group | Function description | Illustrate |
|---------------------|--|--|
| P0 ~ PF | Basic function parameter group | Compatible with KD600M series function codes |
| A0 ~ A3 | Second motor parameter group | The second motor parameters, acceleration and deceleration time, control mode, etc. can be set independently |
| B0 ~ B6 | Enhanced function parameter group | System parameter setting, user function code customization, optimization control, AI/AO correction, master-slave control, brake function and sleep function; |
| C0 ~ CF | Special plane function selection group | Choose to use different professional inverter functions; |
| U0 ~ U1 | Monitoring parameter group | U0 is the fault record parameter group, and U1 is the user monitoring parameter, which is convenient to check the relevant output status; |

4.3 Function code viewing and modification method description

AC drives adopts three-level menu structure for parameter setting and other operations. The three-level menus respectively are: functional parameter group(first-level menu)→function code (second- level menu)-function code setting value (third-level menu). Operational process is shown in Figure 4-2:

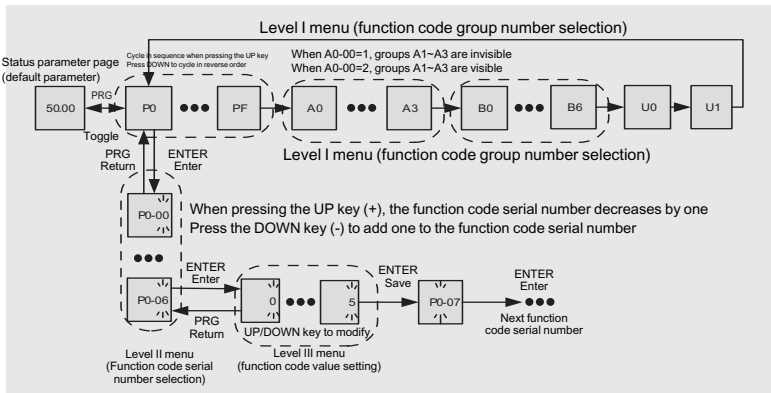

Figure 4-2 Three-level menu operation flow chart

Note:

When operating in the third-level menu, you can press PRG key or ENTER key to return to the second-level menu. But pressing the ENTER key will save the current parameter modification value and transfer to the next function code; while pressing the PRG key will abandon the current parameter modification.

Example: Change function code P1-04 from 0.00Hz to 5.00Hz.

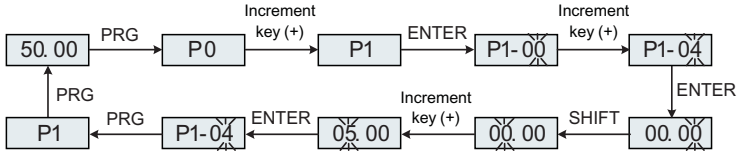

Figure 4-3 Parameter setting operation flow chart

In the third-level menu state, if the parameter has no flashing bit, it means that the parameter value of the function code cannot be modified. For the specific reason, please refer to the description of the function code attribute.



Chapter 5

Synchronous Motor Open Loop Vector (SVC) Commissioning Instructions

| | |
|--|----|
| 5.1 Set the synchronization type, control method and motor parameters..... | 38 |
| 5.2 Parameter identification..... | 38 |
| 5.3 No-load test run..... | 38 |
| 5.4 Quick start test run..... | 39 |
| 5.5 Load and run..... | 39 |

5.1 Set the synchronization type, control method and motor parameters

- 1 The motor type is set to synchronous motor and the control mode is SVC, that is, P0-03=11.

Note:

The ten digit of P0-03 is the motor type selection, and the one digit is the control mode;

Tens place: 1: synchronous motor, 0: asynchronous motor;

Ones place: 1: SVC, 2: VF, 3: Closed loop vector (reserved)

- 2 Set P4-01~P4-06 according to the actual motor parameters.

5.2 Parameter identification

- 1 Connect the motor, if there is a load, set P4-00 to 1; if it is an empty shaft, set P4-00 to 2, the digital tube will display TUNE, in order to ensure the control effect, the motor is best to be no-load and set P4 -00 is 2.
- 2 Press the RUN key to perform parameter identification, and wait for TUNE to disappear, then the parameter identification ends.
- 3 The identification process lasts for about 1 minute, and you can press the STOP button in the middle to exit. During this period, current will be sent, run the motor at the set acceleration and deceleration time to 60% of the rated frequency of the motor to observe whether the motor runs smoothly, if not, press STOP to exit, reach 60% of the rated frequency of the motor, and decelerate to stop after a period of time.
- 4 After parameter identification, check whether the parameters of P4-17~ P4-20 are normal.

5.3 No-load test run

- 1 Set the speed to a smaller range, such as P0-11= 20Hz.
- 2 Press the run key to check whether the motor can accelerate to the set frequency and whether the motor current is small. If the motor can accelerate to the set frequency and the motor current is small, the inverter is basically normal. Set the frequency to the rated frequency of the motor and check whether the motor can accelerate to the set frequency.

5.4 Quick start test run, set it when quick start and stop are required, otherwise skip this step

Reduce the motor acceleration time (for example, set it to 1 second), change the speed loop and current loop PI parameter settings, and press the run key to check whether the motor can quickly accelerate to the set frequency.

5.5 Load and run

After the above 5 steps, you can run the motor with load and use the inverter normally.

Note:

Loading or changing the moment of inertia of the system, if the system response cannot achieve the expected effect, it is necessary to adjust the two parameters P3-04 and P3-06 appropriately. If you replace it with another motor, you generally need to set the rated frequency and rated current of the motor, and then perform parameter identification.



Chapter 6

Troubleshooting and Countermeasures

| | |
|--|----|
| 6.1 Fault alarm and countermeasures..... | 42 |
| 6.2 Common faults and their solutions..... | 47 |
| 6.3 Common faults of synchronous motors and their solutions..... | 49 |

6.1 Fault alarm and countermeasures

If a fault occurs during the system operation, the inverter will immediately protect the motor to stop the output, and the corresponding inverter fault relay contact will act. The inverter panel displays the fault code. The fault type and common solution corresponding to the fault code are shown in the following table. The list in the table is for reference only, please do not repair or modify it without authorization. If the fault cannot be eliminated, please seek technical support from our company or the product agent.

Table 6-1 Fault alarm and countermeasures

| Fault name | Panel display | Troubleshooting | Troubleshooting Countermeasures |
|---------------------------------|---------------|--|---|
| Inverter module protection | Err01 | <ul style="list-style-type: none"> ◆ Whether the motor connection terminals U, V and W are short-circuited between phases or to ground ◆ Is the module overheated? ◆ Whether the internal wiring of the inverter is loose ◆ Whether the main control board, driver board or module is normal | <ul style="list-style-type: none"> ◆ Contact short circuit ◆ Are the fans and air ducts normal? ◆ Connect all loose wires ◆ Seek technical support |
| Overcurrent during acceleration | Err04 | <ul style="list-style-type: none"> ◆ There is grounding or short circuit in the output circuit of the inverter ◆ The motor parameters are incorrect ◆ The acceleration time is too short ◆ V/F torque boost or inappropriate curve ◆ The input voltage is low ◆ Start the rotating motor ◆ Sudden load during acceleration ◆ Inverter selection is too small | <ul style="list-style-type: none"> ◆ Eliminate peripheral faults ◆ Check parameters and parameter identification ◆ Increase the acceleration time ◆ Adjust the V/F boost torque or curve ◆ Adjust the voltage to the normal range ◆ Select the speed tracking start or wait for the motor to stop before starting ◆ Cancel sudden load ◆ Use inverters with larger power levels |

| Fault name | Panel display | Troubleshooting | Troubleshooting Countermeasures |
|---|---------------|---|---|
| Overcurrent during deceleration | Err05 | <ul style="list-style-type: none"> ◆ There is grounding or short circuit in the output circuit of the inverter ◆ The motor parameters are incorrect ◆ The deceleration time is too short ◆ The input voltage is low ◆ Sudden load during deceleration ◆ No braking unit and braking resistor ◆ The magnetic flux braking gain is too large | <ul style="list-style-type: none"> ◆ Eliminate peripheral faults ◆ Perform motor parameter identification ◆ Increase the deceleration time ◆ Adjust the voltage to the normal range ◆ Cancel sudden load ◆ Install braking unit and resistance ◆ Reduce the magnetic flux braking gain |
| Overcurrent in constant speed operation | Err06 | <ul style="list-style-type: none"> ◆ There is grounding or short circuit in the output circuit of the inverter ◆ The motor parameters are incorrect ◆ The input voltage is low ◆ Is there a sudden load during operation? ◆ Inverter selection is too small | <ul style="list-style-type: none"> ◆ Eliminate peripheral faults ◆ Check parameters and parameter identification ◆ Adjust the voltage to the normal range ◆ Cancel sudden load ◆ Select the inverter with a larger power level |
| Overvoltage during acceleration | Err08 | <ul style="list-style-type: none"> ◆ The input voltage is too high ◆ There is an external force driving the motor to run during the acceleration process ◆ The acceleration time is too short ◆ No braking unit and braking resistor ◆ The motor parameters are incorrect | <ul style="list-style-type: none"> ◆ Adjust the voltage to the normal range ◆ Cancel external power or install braking resistor ◆ Increase the acceleration time ◆ Install braking unit and resistor ◆ Check parameters and parameter identification |
| Overvoltage during deceleration | Err09 | <ul style="list-style-type: none"> ◆ The input voltage is too high ◆ There is an external force driving the motor to run during the deceleration process ◆ The deceleration time is too short ◆ No braking unit and braking resistor | <ul style="list-style-type: none"> ◆ Adjust the voltage to the normal range ◆ Cancel external power or install braking resistor ◆ Increase the deceleration time ◆ Install braking unit and resistor |

| Fault name | Panel display | Troubleshooting | Troubleshooting Countermeasures |
|---|---------------|---|---|
| Overvoltage during constant speed operation | Err10 | <ul style="list-style-type: none"> ◆ The input voltage is too high ◆ There is an external force driving the motor to run during the acceleration process | <ul style="list-style-type: none"> ◆ Adjust the voltage to the normal range ◆ Cancel external power or install braking resistor |
| Undervoltage fault | Err12 | <ul style="list-style-type: none"> ◆ Instantaneous power failure ◆ The input voltage of the inverter is not within the range required by the specification ◆ The bus voltage is abnormal ◆ The rectifier bridge and buffer resistance are abnormal ◆ Abnormal drive board ◆ The control panel is abnormal | <ul style="list-style-type: none"> ◆ Reset fault ◆ Adjust the voltage to the normal range ◆ Seek technical support |
| Drive overload fault | Err13 | <ul style="list-style-type: none"> ◆ Whether the load is too large or the motor is blocked ◆ Inverter selection is too small | <ul style="list-style-type: none"> ◆ Reduce the load and check the motor and mechanical conditions ◆ Select the inverter with a larger power level |
| Motor overload fault | Err14 | <ul style="list-style-type: none"> ◆ Whether the setting of motor protection parameter P9-01 is appropriate ◆ Whether the load is too large or the motor is blocked ◆ Inverter selection is too small | <ul style="list-style-type: none"> ◆ Correctly set this parameter ◆ Reduce the load and check the motor and mechanical condition ◆ Select the inverter with a larger power level |
| drive overheating | Err15 | <ul style="list-style-type: none"> ◆ The ambient temperature is too high ◆ The air duct is blocked ◆ The fan is damaged ◆ The module thermistor is damaged ◆ The inverter module is damaged | <ul style="list-style-type: none"> ◆ Lower the ambient temperature ◆ Clean the air duct ◆ Replace the fan ◆ Replace the thermistor ◆ Replace the inverter module |

| Fault name | Panel display | Troubleshooting | Troubleshooting Countermeasures |
|---------------------------|---------------|--|--|
| Current detection failure | Err17 | <ul style="list-style-type: none"> ◆ Whether the internal wiring of the inverter is loose ◆ Is the current detection device normal? ◆ Whether the main control board or driver board is normal | <ul style="list-style-type: none"> ◆ Check the wiring ◆ Seek technical support |
| Short to ground fault | Err20 | <ul style="list-style-type: none"> ◆ Motor short circuit to ground | <ul style="list-style-type: none"> ◆ Replace the cable or motor |
| Input phase loss fault | Err23 | <ul style="list-style-type: none"> ◆ The three-phase input power supply is abnormal ◆ The driver board is abnormal ◆ The lightning protection board is abnormal ◆ The main control board is abnormal | <ul style="list-style-type: none"> ◆ Check and eliminate problems in peripheral circuits ◆ Seek technical support |
| Output phase loss fault | Err24 | <ul style="list-style-type: none"> ◆ The lead wire from the inverter to the motor is abnormal ◆ The three-phase output of the inverter is unbalanced when the motor is running ◆ The driver board is abnormal ◆ Module exception | <ul style="list-style-type: none"> ◆ Eliminate peripheral faults ◆ Check whether the three-phase windings of the motor are normal and troubleshoot ◆ Seek technical support |
| read and write failure | Err25 | <ul style="list-style-type: none"> ◆ EEPROM chip damaged | <ul style="list-style-type: none"> ◆ Replace the main control board |
| Parameter | Err27 | <ul style="list-style-type: none"> ◆ Is the host computer working? ◆ Is the communication connection normal? ◆ Whether the communication parameter P8 group is correct | <ul style="list-style-type: none"> ◆ Check the wiring of the host computer, etc. ◆ Check the communication wiring ◆ Check the parameters of P8 group |
| Parameter | Err28 | <ul style="list-style-type: none"> ◆ Input external normally open or normally closed fault signal through multi-function DI terminal | <ul style="list-style-type: none"> ◆ Fault reset |
| Excessive speed deviation | Err29 | <ul style="list-style-type: none"> ◆ The load is too heavy and the set acceleration time is too short ◆ The setting of fault detection parameters P9-31 and P9-32 is unreasonable | <ul style="list-style-type: none"> ◆ Extend the set acceleration and deceleration time ◆ Reset P9-31 and P9-32 |

| Fault name | Panel display | Troubleshooting | Troubleshooting Countermeasures |
|-----------------------------------|---------------|--|---|
| User-defined fault 1 | Err30 | ◆ User-defined fault 1 signal input through multi-function terminal DI | ◆ Reset |
| User-defined fault 2 | Err31 | ◆ User-defined fault 2 signal input through multi-function terminal DI | ◆ Reset |
| PID feedback lost at runtime | Err32 | ◆ PID feedback value is less than the set value of PA-13 | ◆ Check the feedback signal or reset the PA-13 |
| Fast current limiting | Err33 | ◆ The load is too large or the stall occurs ◆ The set acceleration time is too short | ◆ Reduce the load or replace the inverter with a higher power ◆ Properly extend the acceleration time |
| load drop failure | Err34 | ◆ When the load drop detection condition is reached, please refer to P9-28-P9-30 for specific use. | ◆ Reset or reset detection conditions |
| input power failure | Err35 | ◆ The input voltage is not within the specified range ◆ Power on and off too frequently | ◆ Adjust the input voltage ◆ Extend the power cycle |
| parameter storage exception | Err37 | ◆ Abnormal communication between DSP and EEPROM chip | ◆ Replace the main control board ◆ Seek manufacturer service |
| The running time has arrived | Err39 | ◆ The current running time of the inverter > the set value of P7-38 | ◆ Reset |
| Accumulated running time reached | Err40 | ◆ The accumulated running time reaches the set value P7-20 | ◆ Use parameter initialization function 2 to clear the recording time or reset the accumulated running time |
| Switching motors during operation | Err42 | ◆ Switch the motor through the terminals during operation | ◆ Motor switch after shutdown |

| Fault name | Panel display | Troubleshooting | Troubleshooting Countermeasures |
|--|---------------|--|--|
| Master-slave control communication dropped | Err46 | <ul style="list-style-type: none"> ◆ The master is not set but the slave is set ◆ The communication line is abnormal or the communication parameters are incorrect | <ul style="list-style-type: none"> ◆ Set the host and reset the fault ◆ Check the communication line and communication parameter P8 group |
| SVC shutdown speed feedback abnormal fault | Err47 | <ul style="list-style-type: none"> ◆ It is possible that the motor parameters are not self-learning, and the motor is not connected for abnormal protection | <ul style="list-style-type: none"> ◆ The default time set for P9-09 is 5 seconds, with a set time of 0 seconds. The fault can be turned off within the range of 0 to 100.0 seconds. |

6.2 Common faults and their solutions

The following fault conditions may be encountered during the use of the inverter, please refer to the following methods for simple fault analysis.

Table 6-2 Common faults and their solutions

| Serial number | Fault phenomenon | Possible reason | Solution |
|---------------|-------------------------------------|---|--|
| 1 | No display when power on | <ul style="list-style-type: none"> ◆ The grid voltage is not available or too low ◆ The switching power supply on the drive board of the inverter is faulty ◆ The rectifier bridge is damaged ◆ The buffer resistance of the inverter is damaged ◆ Control panel and keyboard failure ◆ The connection between the control board, the driver board and the keyboard is broken | <ul style="list-style-type: none"> ◆ Check the input power ◆ Check the bus voltage ◆ Re-plug the keyboard and the 30-pin cable ◆ Seek manufacturer service |
| 2 | Display "Err20" alarm when power on | <ul style="list-style-type: none"> ◆ The motor or output line is short-circuited to ground ◆ The inverter is damaged | <ul style="list-style-type: none"> ◆ Use a shaker to measure the insulation of the motor and output line ◆ Seek manufacturer service |

| Serial number | Fault phenomenon | Possible reason | Solution |
|---------------|--|---|---|
| 3 | Err15 (module overheating) fault is reported frequently | <ul style="list-style-type: none"> ◆ The carrier frequency setting is too high ◆ The fan is damaged or the air duct is blocked ◆ The internal components of the inverter are damaged (thermocouple or other) | <ul style="list-style-type: none"> ◆ Reduce the carrier frequency (P0-26) ◆ Replace the fan and clean the air duct ◆ Seek manufacturer service |
| 4 | The motor does not rotate after the inverter is running | <ul style="list-style-type: none"> ◆ Motor and motor wire ◆ Incorrect setting of inverter parameters (motor parameters) ◆ Poor connection between the drive board and the control board ◆ Drive board failure | <ul style="list-style-type: none"> ◆ Reconfirm the connection between the inverter and the motor ◆ Replace the motor or clear the mechanical fault ◆ Check and reset the motor parameters |
| 5 | DI terminal failure | <ul style="list-style-type: none"> ◆ Parameter setting error ◆ External signal error ◆ The position of the DI DIP switch is wrong ◆ Control board failure | <ul style="list-style-type: none"> ◆ Check and reset the relevant parameters of the P5 group ◆ Reconnect the external signal line ◆ Re-confirm whether the position of the DI DIP switch is consistent with the wiring method ◆ Seek manufacturer service |
| 6 | The inverter frequently reports overcurrent and overvoltage faults | <ul style="list-style-type: none"> ◆ The motor parameters are set incorrectly ◆ Inappropriate acceleration and deceleration time ◆ Load fluctuation | <ul style="list-style-type: none"> ◆ Reset the motor parameters or perform motor tuning ◆ Set the appropriate acceleration and deceleration time ◆ Seek manufacturer service |

6.3 Common faults of synchronous motors and their solutions

6.3.1 Motor starts with heavy load

If the motor does not start normally with load, you can try the following operations:

- 1 Increase the upper limit of torque current (P3-21)

When the load is greater than the torque output of the inverter, the inverter will be in a locked-rotor state, and P3-21 can be appropriately increased at this time.

- 2 Increase the speed PI adjustment parameter, modify the resistance value or static identification to correct the motor resistance.

The motor resistance parameter (P4-17) will significantly affect the load carrying capacity of the motor at low speed. When the resistance parameter (P4-17) exceeds the actual resistance value by too much (for example, 200% of the actual resistance value), it may cause the motor to reverse at low speed at the upper torque limit current. When the resistance parameter (P4-17) is too much lower than the actual resistance value (for example, 50% of the actual resistance value), it may cause the motor to run in a step-by-step manner, or rotate for a period of time and stop for a period of time. Increasing the speed P value P3-04 at low speed and reducing the speed loop integral time P3-05 may improve the problem caused by too small resistance parameters.

6.3.2 Adjust the speed loop PI parameters (under normal circumstances do not need to adjust)

- 1 In general, if the proportional coefficient of speed PI adjustment is too large, it will cause high-frequency vibration of the speed, and the mechanical vibration or electromagnetic noise will increase significantly; if the proportional coefficient is too small and the integration time is too small or the load inertia is too large, it will cause low-frequency vibration of the speed and overshoot of the speed. Obviously, if there is no discharge measures, there may be overvoltage.
- 2 If you need to adjust the speed PI parameter, first increase the integral time, increase the ratio if the speed does not oscillate, and then decrease the integral time if the effect is not satisfactory. Generally, the larger the inertia of the system, the smaller the integral time and the larger the proportional coefficient. If the speed filter coefficient is increased, the integral time should be increased, and the proportion can be increased appropriately.

Note:

The inertia of the drive system is equal to the motor inertia plus the load inertia. The inertia of the motor is proportional to the mass of the motor and the square of the diameter of the motor; the inertia of the transmission load is proportional to the mass of the load and the square of the diameter of the transmission wheel; if there is a deceleration or speed-up device, the inertia is proportional to the speed-up ratio and inversely proportional to the deceleration ratio .

For loads with large inertia, if fast speed response is required, the integration time needs to be reduced, but it is easy to cause speed overshoot, resulting in overvoltage of the inverter, and a discharge device is required to discharge. If there is no discharge device, the integration time can be increased.

6.3.3 Adjust the PI parameters of the current loop (under normal circumstances, do not need to adjust)

Under normal circumstances, increasing the proportional coefficient and the integral coefficient will speed up the current response speed, but if too large, it will cause speed shock (specifically, the motor does not rotate, or rotates in random directions, and emits high-frequency electromagnetic noise at the same time). If you need to adjust it, first Adjust the proportional coefficient, and adjust the integral coefficient if the effect is not satisfactory. The PI parameters of the current loop are related to the motor stator resistance, inductance, carrier frequency of the system, and current sampling filter time. When the carrier frequency of the system remains unchanged, the proportional coefficient is proportional to the inductance, and the integral coefficient is proportional to the resistance. Therefore, by identifying The output parameter can roughly determine the adjustment direction of this parameter.



Chapter 7

Modbus communication protocol

| | |
|---|----|
| 7.1 Communication frame structure..... | 52 |
| 7.2 Address Definition of Communication Parameters..... | 54 |

KD600M series inverter provides RS232/RS485 communication interface and supports Modbus communication protocol. Users can realize centralized control through computer or PLC, set inverter running commands, modify or read function code parameters, and read inverter working status and fault information through this communication protocol.

7.1 Communication frame structure

RTU frame format:

| | |
|-------------------------|--|
| Frame header START | 3.5 character time |
| Slave address ADR | Communication address: 1 ~ 247 (set by P8-02) |
| Command code CMD | 03: Read slave parameters; 06: Write slave parameters |
| Data content DATA (N-1) | Data content: Function code parameter address, function code parameter number, function code parameter value, etc. |
| Data content DATA (N-2) | |
| ... | |
| Data content DATA0 | |
| CRC CHK low order | Detection value: CRC16 check value. When transmitting, the low byte comes first and the high byte follows. For the calculation method, please refer to the description of CRC check in this section. |
| CRC CHK high bits | |
| END | 3.5 character time |

Command command (CMD) and data description (DATA)

Command code: 03H, read N words (Word), can read up to 12 words and N=1~ 12. The specific format is as follows:

Host read command frame

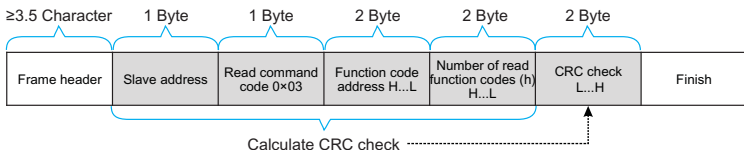

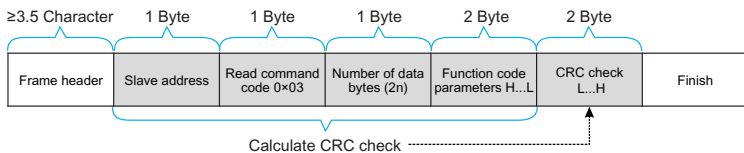
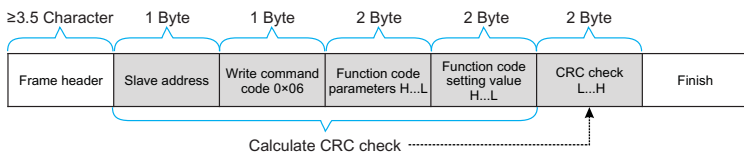
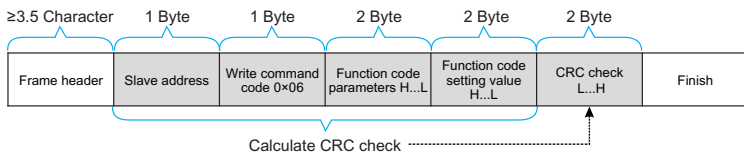
Slave read response frame**Host write command frame****Slave write response frame**

If the slave detects a communication frame error, or fails to read and write due to other reasons, it will reply with an error frame. Slave read response error frame:

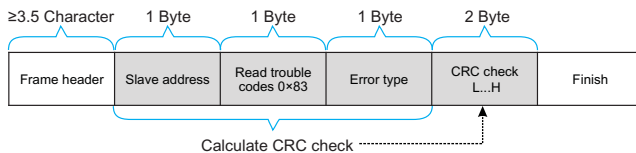
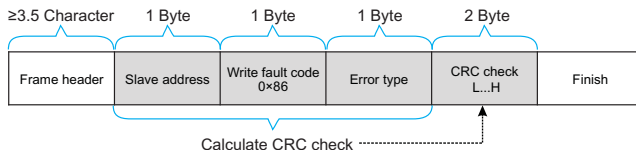
**Slave write response error frame**

Example: read the contents of two consecutive parameters starting from P0-03 of the inverter whose slave address P8-02 is 01.

The frame sent by the host is shown in the figure:

| | | | | | | |
|--------------------------------|-----------------------|---------------------------|---------------------------------------|---|------------------------|--------|
| Frame header ≥3.5 Character | Slave address 0×01 | Read command code 0×03 | Function code address 0×F0 0×03 | Number of read function codes 0×00 0×02 | CRC check 0×07 0×0B | Finish |
|--------------------------------|-----------------------|---------------------------|---------------------------------------|---|------------------------|--------|

The slave reply frame is as shown in the figure:

| | | | | | | | |
|-----------------------------------|-----------------------|------------------------------|--------------------|--|--|------------------------|--------|
| Frame header ≥3.5 Character | Slave address 0×01 | Read command code 0×03 | Data bytes 0×04 | P0.03 parameter value 0×00 0×00 | P0.04 parameter value 0×00 0×00 | CRC check 0×FA 0×33 | Finish |
|-----------------------------------|-----------------------|------------------------------|--------------------|--|--|------------------------|--------|

Note: If the write command is unsuccessful, the failure reason will be returned.

7.2 Address Definition of Communication Parameters

This part is the content of communication, which is used to control the operation of the inverter, the status of the inverter and the setting of related parameters.

Read and write function code parameters (some function codes cannot be changed, and are only used by manufacturers or monitored):

Function code parameter address marking rules:

The rules are represented by the function code group number and label as the parameter address:

High-order byte: P0~PF (group P), A0~AF (group A), B0~BF (group B), C0~CF (group C),

D0~DF (group D), 70~7F (group U) low byte: 00~PF

Such as: P0-11, the address is expressed as F00B;

Notice:

PF group: parameters can neither be read nor changed;

Group U: can only be read, parameters cannot be changed.

Some parameters cannot be changed when the inverter is running; some parameters cannot be changed no matter what state the inverter is in; when changing the function code parameters, pay attention to the range, unit, and related descriptions of the parameters.

| Function code group | Communication visit address | Function code address of communication change RAM |
|---------------------|-----------------------------|---|
| P0 ~ PE | 0xF000 ~ 0xPEPF | 0x0000 ~ 0x0EPPF |
| A0 ~ AF | 0xA000 ~ 0xAPFF | 0x4000 ~ 0x4PFF |
| B0 ~ BF | 0xB000 ~ 0xBPFF | 0x5000 ~ 0x5PFF |
| C0 ~ CF | 0xC000 ~ 0xCPFF | 0x6000 ~ 0x6PFF |
| U0, U1 | 0x70xx, 0x71xx | |

Note that, because the EEPROM is frequently stored, the service life of the EEPROM will be reduced. Therefore, some function codes do not need to be stored in the communication mode, just change the value in the RAM.

If it is a parameter of group P, to realize this function, it can be realized only by changing the high-order F of the function code address to 0.

If it is a group A parameter, to realize this function, just change the high-order A of the function code address to 4 to realize it.

The corresponding function code addresses are expressed as follows: high byte: 00~0F (group P), 40~4F (group A) low byte: 00~PF

For example, the function code P0-11 is not stored in the EEPROM, and the address is expressed as 000B; this address indicates that it can only be written to RAM, but cannot be read. When reading, it is an invalid address.

Stop/Run parameter section:

| Address | Parameter Description |
|-------------------|--|
| 0X1000/ 0X9000 | 1000: *communication setting value (-10000~10000) (decimal) (unit: 0.01%), readable and writable |
| | 9000: Communication setting frequency: 0HZ~P0-14 (minimum unit: 0.01HZ), readable and writable |
| 0x1001 | Set frequency (unit: 0.01Hz), read only |
| 0x1002 | Running frequency (unit: 0.01Hz), read only |
| 0x1003 | Bus voltage (unit: 0.1V), read only |
| 0x1004 | Output voltage (unit: 0.1V), read only |
| 0x1005 | Output current (unit: 0.1A), read only |
| 0x1006 | Output power (unit: 0.1kW), read only |
| 0x1007 | DI input flag (unit: 1), read only |

| Address | Parameter Description |
|---------|--|
| 0x1008 | DO output flag (unit: 1), read only |
| 0x1009 | PID setting (unit: 1), read only |
| 0x100A | PID feedback (unit: 1), read only |
| 0x100B | AI1 voltage (unit: 0.01V), read only |
| 0x100C | AI2 voltage (unit: 0.01V), read only |
| 0x100D | AO1 output voltage (unit: 0.01V) read only |
| 0x100E | PLC step (unit: 1), read only |
| 0x100F | Speed (unit: 1rpm), read only |
| 0x1010 | Count value input (unit: 1), read only |
| 0x1011 | Input pulse frequency (unit: 0.01kHz), read only |
| 0x1012 | Feedback speed (unit: 0.1Hz), read only |
| 0x1013 | Remaining running time (unit: 0.1min), read only |

Example 1:

Read the operating frequency of the first device: 0x01 0x03 0x10 0x02 0x00 0x01 0x21 0x0A

0x10 0x02 (1002) operating frequency address, 0x00 0x01 (0001) a data

0x21 0x0A (210A) CRC check value

Example 2:

Read the bus voltage, output voltage and output current of the first device at the same time: 0x01 0x03 0x10 0x03 0x00 0x03 CRC check value, the meaning of the data is similar to that of example 1.

Note:

The communication setting value is a percentage of the relative value, 10000 corresponds to 100.00%, -10000 corresponds to -100.00%.

For frequency dimension data, the percentage is relative to the maximum frequency (P0-14); for torque dimension data, the percentage is P3-21, P3-23, A3-21, A3-23.

Note:

DO output terminal needs to select 16 (communication control) function.

AO output needs to select 7 (communication control output) function.

| Type | Command address | Command content |
|--|-----------------|--|
| Control command input (write only) | 0x2000 | 0001: Forward run 0002: Reverse run 0003: Forward jog 0004: Reverse jog 0005: Coast to stop 0006: Decelerate to stop 0007: Fault reset 0008: Fault reset (only in communication control mode can fault reset) |
| Status read (read only) | 0x3000 | 0001: Forward running 0002: Reverse running 0003: Stop |
| Digital output terminal control (write only) | 0x2001 | BIT0: RELAY1 output control BIT1: DO1 output control BIT2: RELAY2 output control |
| Analog output AO1 control (write only) | 0x2002 | 0 ~ 7PFF means 0% ~ 100% |
| Analog output AO2 control (write only) | 0x2003 | 0 ~ 7PFF means 0% ~ 100% |
| Inverter fault address | 0x8000 | 0000: No fault 0001: Reserved 0002: Reserved 0003: Reserved 0004: Acceleration overcurrent 0005: Deceleration overcurrent 0006: Constant speed overcurrent 0007: Stop overcurrent 0008: Acceleration overvoltage 0009: Deceleration overvoltage 000A: Constant speed overvoltage 000B: Stop overvoltage 000C: Undervoltage fault 000D: Inverter overload 000E: Motor overload 000F: Module overheat 0010: Reserved 0011: Current detection fault 0012: Reserved 0013: Reserved 0014: Motor short circuit fault to ground 0015: Motor tuning fault 0016: Reserved |

| Type | Command address | Command content |
|------------------------|-----------------|---|
| Inverter fault address | 0x8000 | 0017: Input phase loss 0018: Output phase loss 0019: EEPROM read and write abnormality 001A: Password input exceeded times 001B: Communication abnormal 001C: External fault 001D: Excessive speed deviation 001E: User-defined fault 1 001F: User-defined fault 2 0020: Loss of PID feedback during runtime 0021: Hardware current limit fault 0022: Loss of load 0023: Overload fault of buffer resistor 0024: The contactor is abnormal 0025: The agent running time has arrived 0026: Motor over temperature (reserved) 0027: Current running time reached 0028: Cumulative running time reached 0029: Power-on time reached 002A: Switching motor failure during operation 002B: Motor overspeed 002C: Reserved 002D: Reserved 002E: reserved 002F: point-to-slave fault |

The return address when communication fails: read fault 83XX, write fault 86X.



Chapter 8

Function & Parameter Table

| | |
|---------------------------|----|
| 8.1 Functional group..... | 60 |
|---------------------------|----|

The function code symbols are explained as follows:

| Icons | Content |
|-------|---|
| ☆ | Indicates that the inverter parameters can be modified during stop and running (0) |
| ★ | Indicates that the inverter is in a running state and cannot be modified (1) |
| ○ | Indicates that this parameter is a manufacturer's parameter and cannot be changed by the user (3) |
| ● | Indicates the actual detection value of the inverter or the manufacturer's fixed value, which cannot be changed (2) |

The communication address in the function parameter table is written in hexadecimal.

Enhanced function codes: Group A0~Group A3, Group B0~Group B6, opened by function parameter P7-75.

| Function code | Name | Description (setting range) | Factory Default | Change |
|---------------------------------------|--------------------------|---|---------------------|--------|
| Group P0: Basic function group | | | | |
| P0-00 | Product number | Product model: 5 digits display, 2 decimal places | 60#.## | ● |
| P0-01 | Inverter GP type display | 0: G type 1: P type | 0 | ★ |
| P0-02 | Rated current | 0.1A ~ 3000.0A | Model is determined | ● |
| P0-03 | Motor control method | Ones place: motor control mode selection 1: Open loop vector control (speed sensorless vector) 2: VF Control Tens place: motor type selection 0: Asynchronous motor 1: Synchronous motor | 2 | ★ |
| P0-04 | Run command source | 0: Operation panel running command channel (LED off) 1: Terminal command channel (LED on) 2: Communication command channel (LED flashes) | 0 | ★ |

| Function code | Name | Description (setting range) | Factory Default | Change |
|---------------|--|---|-----------------|--------|
| P0-05 | Up\Down to modify the frequency command reference during runtime | 0: Running frequency 1: Setting frequency | 1 | ★ |
| P0-06 | Main frequency source X selection | 0: Up/Down frequency modification, shutdown not remembered 1: Up/Down Modify Frequency Power Failure Memory 2: Ai1 3: Reserved 4: Multi stage speed 5: Simple PLC 6: PID 7: Communication given 8: PULSE pulse setting 9: Up/Down modification frequency, shutdown memory, power-off memory, no memory | 1 | ★ |
| P0-07 | Auxiliary frequency source Y selection | 0: Up/Down frequency modification, shutdown not remembered 1: Up/Down Modify Frequency Power Failure Memory 2: Ai1 3: Reserved 4: Multi stage speed 5: Simple PLC 6: PID 7: Communication given 8: PULSE pulse setting 9: Up/Down modification frequency, shutdown memory, power-off memory, no memory | 0 | ★ |
| P0-08 | Auxiliary frequency source Y range selection | 0: relative to the maximum frequency 1: Relative to frequency source X 2: The range is the same as 0 but the main and auxiliary have no negative frequency output | 0 | ☆ |

Chapter 8 Function & Parameter Table

| Function code | Name | Description (setting range) | Factory Default | Change |
|---------------|------------------------------------|--|-----------------|--------|
| P0-09 | Auxiliary frequency source Y range | 0% to 100% | 100% | ☆ |
| P0-10 | Frequency source selection | <p>Ones place: frequency source selection</p> <p>0: Main frequency source X</p> <p>1: Main and auxiliary operation results (the operation relationship is determined by ten digits)</p> <p>2: Switch between main frequency source X and auxiliary frequency source Y</p> <p>3: Switch between the main frequency source X and the main and auxiliary operation results</p> <p>4: Switch between auxiliary frequency source Y and main and auxiliary operation results</p> <p>Tens place: main and auxiliary operation relationship of frequency source</p> <p>0: main + auxiliary</p> <p>1: Primary-Secondary</p> <p>2: the maximum value of the two</p> <p>3: the minimum value of the two</p> | 00 | ☆ |
| P0-11 | Preset frequency | 0.00Hz ~ Maximum frequency P0-14 | 50.00Hz | ☆ |
| P0-13 | Motor running direction selection | <p>0: Consistent with the current motor direction</p> <p>1: Opposite to the current motor direction</p> <p>2: Inversion is prohibited</p> | 0 | ☆ |
| P0-14 | Maximum output frequency | <p>When P0-20=1, the adjustable range is 50.0Hz ~ 1200.0Hz;</p> <p>When P0-20=2, the adjustable range is 50.00Hz ~ 600.00Hz;</p> | 50.00Hz | ★ |
| P0-15 | Upper limit frequency source | <p>0: Number given (P0-16)</p> <p>1: Ai1</p> <p>2: Reserved</p> <p>3: Communication given</p> <p>4: PULSE setting</p> | 0 | ★ |

| Function code | Name | Description (setting range) | Factory Default | Change |
|---------------|--|---|-----------------|--------|
| P0-16 | Upper limit frequency | Lower limit frequency P0-18 ~ maximum frequency P0-14 | 50.00Hz | ☆ |
| P0-17 | Upper limit frequency offset | 0.00 ~ Maximum frequency P0-14 | 0.00Hz | ☆ |
| P0-18 | Lower frequency | 0.00Hz ~ upper limit frequency P0-16 | 0.00Hz | ☆ |
| P0-19 | Command source binding selection | Bit: Operation panel command binding frequency source selection 0: Unbound 1: Digital setting frequency 2: Ai1 3: Reserved 4: Multi stage speed 5: Simple PLC 6: PID 7: Communication given 8: PULSE pulse setting (Di5) Ten digit: Terminal command binding frequency source selection Hundred bit: Communication command binding frequency source selection Thousand digits: reserved | 000 | ☆ |
| P0-20 | Frequency Decimal Selection | 1: 1 decimal point 2: 2 decimal places | 2 | ★ |
| P0-21 | Acceleration and deceleration time unit | 0: 1 second 1: 0.1 seconds 2: 0.01 seconds | 1 | ★ |
| P0-22 | Acceleration and deceleration time reference frequency | 0: Maximum frequency (P0-14) 1: Preset frequency (P0-11) 2: Motor rated frequency (P4-05 or A1-05) | 0 | ★ |
| P0-23 | Acceleration time 1 | 0s ~ 30000s(P0-21=0) 0.0s ~ 3000.0s(P0-21=1) 0.00s ~ 300.00s(P0-21=2) | 10.0s | ☆ |
| P0-24 | Deceleration time 1 | 0s ~ 30000s(P0-21=0) 0.0s ~ 3000.0s(P0-21=1) 0.00s ~ 300.00s(P0-21=2) | 10.0s | ☆ |

Chapter 8 Function & Parameter Table

| Function code | Name | Description (setting range) | Factory Default | Change |
|-------------------------------------|--|--|---------------------|--------|
| P0-25 | Overmodulation voltage boost value | 0% ~ 10% | 3% | ★ |
| P0-26 | Carrier frequency | 0.5kHz ~ 16.0kHz | Model is determined | ☆ |
| P0-27 | The carrier frequency is adjusted with temperature | 0: Invalid; 1: Valid; | 1 | ☆ |
| P0-28 | Parameter initialization | 0: No operation 1: Restore factory parameters, excluding motor parameters, record information and frequency decimal point P0-20 2: Clear record information 3: Backup current user parameters 4: Restore user backup parameters | 0 | ★ |
| P0-29 | Upload to keyboard and download to frequency converter parameter selection (optional external keyboard implementation) | 0: No function 1: Upload parameters 2: Download P4/A1 group parameters 3: Download parameters other than P4/A1 groups 4: Download all parameters 5: Download P4/A1 group modification item parameters 6: Download parameters for modified items except for P4/A1 groups 7: Download all modified parameters | 0 | ☆ |
| Group P1: Start-stop control | | | | |
| P1-00 | Start method | 0: Direct start 1: Speed Tracking 2: Asynchronous motor pre-excitation start | 0 | ☆ |
| P1-01 | Speed tracking method | 0: start from stop frequency 1: Start with target frequency 2: start from maximum frequency | 0 | ★ |
| P1-02 | Maximum speed tracking current | 30% ~ 150% | 100% | ★ |
| P1-03 | Speed tracking speed | 1 ~ 100 | 20 | ☆ |

| Function code | Name | Description (setting range) | Factory Default | Change |
|---------------|--|--|-----------------|--------|
| P1-04 | Start frequency | 0.00Hz ~ 10.00Hz | 0.00Hz | ☆ |
| P1-05 | Start frequency hold time | 0.0s ~ 100.0s | 0.0s | ★ |
| P1-06 | Start DC braking current | 0% ~ 100% | 0% | ★ |
| P1-07 | Start DC braking time | 0.0s ~ 100.0s | 0.0s | ★ |
| P1-08 | Selection of acceleration and deceleration frequency curve mode | 0: Straight line 1: S curve A 2: S curve B (P1-09 ~ P1-12 unit is 0.01s) | 0 | ★ |
| P1-09 | S-curve acceleration start time | 0.0% ~ 100.0% | 20.0% | ★ |
| P1-10 | S-curve acceleration end time | 0.0% ~ 100.0% | 20.0% | ★ |
| P1-11 | S-curve deceleration start time | 0.0% ~ 100.0% | 20.0% | ★ |
| P1-12 | S-curve deceleration end time | 0.0% ~ 100.0% | 20.0% | ★ |
| P1-13 | Stop mode | 0: Decelerate to stop 1: Free stop | 0 | ☆ |
| P1-14 | DC braking start frequency at stop | 0.00Hz ~ P0-14 | 0.00Hz | ☆ |
| P1-15 | DC braking waiting time at stop | 0.0s ~ 100.0s | 0.0s | ☆ |
| P1-16 | Stop braking DC current | 0% ~ 100% | 0% | ☆ |
| P1-17 | DC braking time at stop | 0.0s ~ 36.0s | 0.0s | ☆ |
| P1-21 | Demagnetization time | 0.01s ~ 3.00s | 0.50s | ★ |
| P1-23 | Instantaneous stop and non-stop mode selection | 0: invalid 1: Automatically adjust the deceleration rate 2: Decelerate to stop | 0 | ★ |
| P1-24 | The deceleration time of the momentary stop and non-stop deceleration stop | 0.0s ~ 100.0s | 10.0s | ★ |
| P1-25 | Instantaneous power failure and non-stop effective voltage | 60% ~ 85% | 80% | ★ |
| P1-26 | Instantaneous power failure and non-stop recovery of voltage | 85% ~ 100% | 90% | ★ |
| P1-27 | Instantaneous power failure and non-stop recovery voltage judgment | 0.0s ~ 300.0s | 0.3s | ★ |

Chapter 8 Function & Parameter Table

| Function code | Name | Description (setting range) | Factory Default | Change |
|---|--|---|---------------------|--------|
| P1-28 | Instantaneous stop and non-stop automatic gain adjustment | 0 ~ 100 | 40 | ☆ |
| P1-29 | Instantaneous stop and non-stop automatic adjustment of integral | 1 ~ 100 | 20 | ☆ |
| Group P2: V/F control parameters | | | | |
| P2-00 | V/F curve setting | 0: Straight line VF curve 1: Multi-point VF curve 2: Square VF curve 3: 1.7th power curve 4: 1.5 power curve 5: 1.3 power curve 6: VF full separation mode 7: V/F half separation mode | 0 | ★ |
| P2-01 | Torque boost | 0.0% ~ 30.0% | 0.0% | ☆ |
| P2-02 | Torque boost cut-off frequency | 0.00Hz ~ Maximum frequency | 25.00Hz | ★ |
| P2-03 | V/F frequency point P1 | 0.00Hz ~ P2-05 | 1.30Hz | ★ |
| P2-04 | V/F voltage point V1 | 0.0% ~ 100.0% | 5.2% | ★ |
| P2-05 | V/F frequency point P2 | P2-03 ~ P2-07 | 2.50Hz | ★ |
| P2-06 | V/F voltage point V2 | 0.0% ~ 100.0% | 8.8% | ★ |
| P2-07 | V/F frequency point P3 | 0.00Hz ~ 50.00 Hz | 15.00Hz | ★ |
| P2-08 | V/F voltage point V3 | 0.0% ~ 100.0% | 35.0% | ★ |
| P2-09 | Slip Compensation Coefficient | 0.0% ~ 200.0% | 50.0% | ☆ |
| P2-10 | Flux Brake Gain | 0 ~ 200 | 100 | ☆ |
| P2-11 | Oscillation suppression gain | 0 ~ 100 | Model is determined | ☆ |
| P2-13 | VF slip compensation time constant | 0.02s ~ 1.00s | 0.30s | ☆ |
| P2-15 | Output voltage source selection when VF is separated | 0: Digital setting (P2-14) 1: AI1 2: Reserve 3: Multi-segment instruction 4: Simple PLC 5: PID | 0 | ☆ |

| Function code | Name | Description (setting range) | Factory Default | Change |
|--|--|---|-----------------|--------|
| P2-15 | Output voltage source selection when VF is separated | 6: Communication given 7: PULSE pulse setting (Di5) 100.0% corresponds to the rated voltage of the motor | 0 | ☆ |
| P2-16 | V/F separation output voltage digital setting | 0V ~ Motor rated voltage | 0V | ☆ |
| P2-17 | V/F separation output voltage acceleration time | 0.0 ~ 3000.0s | 1.0s | ☆ |
| P2-18 | V/F separation output voltage deceleration time | 0.0 ~ 3000.0s | 1.0s | ☆ |
| P2-19 | V/F separation and stop mode selection | 0: Frequency and output voltage deceleration time are independent 1: After the voltage is reduced to 0, the frequency is reduced again | 0 | ☆ |
| Group P3: Vector control parameters | | | | |
| P3-00 | Switching frequency P1 | 0.00 ~ P3-02 | 5.00 Hz | ☆ |
| P3-02 | Switching frequency P2 | P3-00 ~ P0-14 | 10.00 Hz | ☆ |
| P3-04 | Low frequency speed proportional gain | 0.1 ~ 10.0 | 4.0 | ☆ |
| P3-05 | Low frequency speed integration time | 0.01s ~ 10.00s | 0.50s | ☆ |
| P3-06 | High frequency speed proportional gain | 0.1 ~ 10.0 | 2.0 | ☆ |
| P3-07 | High frequency speed integration time | 0.01 ~ 10.00s | 1.00s | ☆ |
| P3-08 | Speed loop integral attribute selection | 0: Points take effect 1: Integral separation | 0 | ★ |
| P3-11 | Torque current regulator Kp | 0 ~ 30000 | 2200 | ☆ |
| P3-12 | Torque current regulator Ki | 0 ~ 30000 | 1500 | ☆ |
| P3-13 | Excitation current regulator Kp | 0 ~ 30000 | 2200 | ☆ |
| P3-14 | Excitation current regulator Ki | 0 ~ 30000 | 1500 | ☆ |
| P3-15 | Flux Brake Gain | 0 ~ 200 | 0 | ☆ |

Chapter 8 Function & Parameter Table

| Function code | Name | Description (setting range) | Factory Default | Change |
|--|--|---|-----------------|--------|
| P3-16 | Field weakening torque correction factor | 50% ~ 200% | 100% | ☆ |
| P3-17 | Slip compensation gain | 50% ~ 200% | 100% | ☆ |
| P3-18 | Speed loop feedback filter time constant | 0.000 ~ 1.000s | 0.015s | ☆ |
| P3-19 | Speed loop output filter time constant | 0.000 ~ 1.000s | 0.000s | ☆ |
| P3-20 | Electric torque upper limit source | 0: P3-21 1: AI1 2: Reserve 3: Communication given 4: PLUSE given (The analog range corresponds to P3-21) | 0 | ☆ |
| P3-21 | Electric torque upper limit | 0.0% ~ 200.0% | 150.0% | ☆ |
| P3-22 | Braking torque upper limit source | 0: P3-23 1: AI1 2: Reserve 3: Communication given 4: PLUSE given (The analog range corresponds to P3-23) | 0 | ☆ |
| P3-23 | Braking torque upper limit | 0.0 ~ 200.0% | 150.0% | ☆ |
| P3-24 | Low-speed magnetizing current of synchronous motor | 0.0% ~ 50.0% | 25.0% | ★ |
| P3-25 | Magnetizing cut-off frequency of synchronous motor | 0% ~ 100% | 10% | ★ |
| P3-26 | Pre-excitation time | 0s ~ 5s | 0.1s | ★ |
| P3-27 | Synchronous motor initial position identification enable selection | 0: Disable 1: Identification method 1 2: Identification method 2 | 1 | ★ |
| P3-28 | Initial position identification voltage given percentage | 30% ~ 130% | 80% | ★ |
| Group P4: First motor parameter | | | | |
| P4-00 | Motor parameter tuning | 0: no function 1: Static tuning 2: Rotary tuning | 0 | ★ |

| Function code | Name | Description (setting range) | Factory Default | Change |
|---------------|--------------------------------------|--|---------------------|--------|
| P4-01 | Motor 1 rated power | 0.1kw ~ 1000.0kw | Model is determined | ★ |
| P4-02 | Motor 1 rated voltage | 1V ~ 1500V | 380V | ★ |
| P4-03 | Motor 1 Number of motor poles | 2 to 64 | Model is determined | ○ |
| P4-04 | Motor 1 rated current | 0.01A ~ 600.00A(Motor rated power<=30.0KW) 0.1A ~ 6000.0A(Motor rated power>30.0KW) | P4-01 OK | ★ |
| P4-05 | Motor 1 rated frequency | 0.01Hz ~ P0-14 | 50.00 Hz | ★ |
| P4-06 | Motor 1 rated speed | 0rpm ~ 60000rpm | P4-01 OK | ★ |
| P4-07 | Motor 1 no-load current | 0.01A ~ P4-04 (Motor rated power<=30.0KW) 0.1A ~ P4-04 (Motor rated power>30.0KW) | Model is determined | ★ |
| P4-08 | Motor 1 stator resistance | 0.001Ω ~ 65.535Ω | Model is determined | ★ |
| P4-09 | Motor 1 rotor resistance | 0.001Ω ~ 65.535Ω | Model is determined | ★ |
| P4-10 | Motor 1 mutual inductance | 0.1Mh ~ 6553.5Mh | Model is determined | ★ |
| P4-11 | Motor 1 leakage inductance | 0.01Mh ~ 655.35Mh | Model is determined | ★ |
| P4-12 | Acceleration at Dynamic Full Tuning | 1.0s ~ 6000.0s | 10.0s | ☆ |
| P4-13 | Deceleration at dynamic full tuning | 1.0s ~ 6000.0s | 10.0s | ☆ |
| P4-17 | Synchronous motor stator resistance | 0.001Ω ~ 65.535Ω | Model is determined | ★ |
| P4-18 | Synchronous motor D-axis inductance | 0.01Mh ~ 655.35Mh | Model is determined | ★ |
| P4-19 | Synchronous motor Q-axis inductance | 0.01Mh ~ 655.35Mh | Model is determined | ★ |
| P4-20 | Synchronous motor back EMF | 1V ~ 65535V | Model is determined | ★ |
| P4-21 | No-load current of synchronous motor | 0.0% ~ 50.0% | 10.0% | ★ |

Chapter 8 Function & Parameter Table

| Function code | Name | Description (setting range) | Factory Default | Change |
|---------------------------------|-----------------------|--|-----------------|--------|
| Group P5: Input terminal | | | | |
| P5-00 | DI1 terminal function | 0: No function 1: Forward rotation (FWD) 2: Reverse operation (REV) 3: Three-wire running control 4: Forward jog (FJOG) 5: Reverse Jog (RJOG) 6: Terminal UP 7: Terminal DOWN | 1 | ★ |
| P5-01 | DI2 terminal function | 8: Free parking 9: Fault reset (RESET) 10: run pause 11: External fault normally open input 12: Multi-segment command terminal 1 13: Multi-segment command terminal 2 14: Multi-segment command terminal 3 15: Multi-segment command terminal 4 | 2 | ★ |
| P5-02 | DI3 terminal function | 16: Acceleration and deceleration selection terminal 1 17: Acceleration and deceleration selection terminal 2 18: Frequency source switching 19: UP/DOWN setting clear (terminal, keyboard) 20: Running command switching terminal | 9 | ★ |
| P5-03 | DI4 terminal function | 21: Acceleration and deceleration prohibition 22: PID invalid (pause) 23: PLC status reset 24: Swing frequency pause 25: Timing trigger input 26: Immediate DC braking 27: External fault normally closed input | 12 | ★ |

| Function code | Name | Description (setting range) | Factory Default | Change |
|---------------|------------------------------|---|-----------------|--------|
| | | 28: Counter input 31: Length count reset 32: Torque control prohibited 33: PULSE (pulse) frequency input 34: Frequency modification prohibited 35: PID action direction is reversed 36: External parking terminal 1 37: Control command switching terminal 2 38: PID integral pause terminal 39: Frequency source X and preset frequency switching terminal 40: Frequency source Y and preset frequency switching terminal 41: Switch between motor 1 and motor 2 42: Reserved 43: PID parameter switching terminal 44: Speed control/torque control switching 45: Emergency stop 46: External parking terminal 2 47: Deceleration DC braking 48: This running time is cleared 49: Two-wire/three-wire switch 50: Inversion prohibited 51: User-defined fault 1 52: User-defined fault 2 53: Sleep Input | | |
| P5-10 | DI terminal filter time | 0.000 ~ 1.000s | 0.010s | ☆ |
| P5-11 | Terminal command method | 0: Two-wire type 1 1: Two-wire type 2 2: Three-wire type 1 3: Three-wire type 2 | 0 | ★ |
| P5-12 | Terminal UP/DOWN change rate | 0.01Hz/s ~ 100.00Hz/s | 1.00Hz/s | ☆ |

Chapter 8 Function & Parameter Table

| Function code | Name | Description (setting range) | Factory Default | Change |
|---------------|---|---|-----------------|--------|
| P5-13 | Terminal valid logic 1 | 0: High level 1: low level Ones place: DI1; Tens place: DI2; Hundreds: DI3; Thousands: DI4; Ten thousand: DI5 | 00000 | ★ |
| P5-15 | AI1 minimum input value | 0.00~P5-17 | 0.00V | ☆ |
| P5-16 | AI1 minimum input corresponding setting | -100.0% ~ 100.0% | 0.0% | ☆ |
| P5-17 | AI1 maximum input value | P5-15~10.00V | 10.00V | ☆ |
| P5-18 | AI1 maximum input corresponding setting | -100.0% ~ 100.0% | 100.0% | ☆ |
| P5-19 | AI1 input filter time | 0.00s ~ 10.00s | 0.10s | ☆ |
| P5-30 | PULSE (pulse) input minimum frequency | 0.00KHz~P5-32 | 0.00KHz | ☆ |
| P5-31 | PULSE (pulse) input minimum frequency corresponding setting | -100.0% ~ 100.0% | 0.0% | ☆ |
| P5-32 | PULSE (pulse) input maximum frequency | P5-30~50.00KHz | 50.00KHz | ☆ |
| P5-33 | PULSE (pulse) input maximum frequency corresponding setting | -100.0% ~ 100.0% | 100.0% | ☆ |
| P5-34 | PULSE input filter time | 0.00s ~ 10.00s | 0.10s | ☆ |
| P5-35 | DI1 turn-on delay time | 0.0s ~ 3600.0s | 0.0s | ☆ |
| P5-36 | DI1 off delay time | 0.0s ~ 3600.0s | 0.0s | ☆ |
| P5-37 | DI2 turn-on delay time | 0.0s ~ 3600.0s | 0.0s | ☆ |
| P5-38 | DI2 off delay time | 0.0s ~ 3600.0s | 0.0s | ☆ |
| P5-39 | DI3 turn-on delay time | 0.0s ~ 3600.0s | 0.0s | ☆ |
| P5-40 | DI3 off delay time | 0.0s ~ 3600.0s | 0.0s | ☆ |
| P5-41 | AI1 is selected as DI terminal function | 0 ~ 53, the function is the same as the common DI terminal | 0 | ★ |

| Function code | Name | Description (setting range) | Factory Default | Change |
|----------------------------------|--|---|-----------------|--------|
| P5-44 | Valid mode selection when AI is used as DI terminal | Individual bits, Ai1: 0: Effective at high level, 1: Low level effective Tenth place: reserved Hundred places: reserved | 0x00 | ☆ |
| P5-45 | AI curve selection | AI multi-point curve selection: Unit: Ai1 0:2 point straight line P5-15~P5-19 1: Multipoint curve 1: PE-00~PE-07 2: Multipoint curve 2: PE-08 to PE-15 Tenth place: reserved | 0x00 | ☆ |
| Group P6: Output terminal | | | | |
| P6-00 | Control board relay RELAY1 output (TA/TB/TC) selection | 0: No output 1: Inverter running signal (RUN) 2: fault output 3: Frequency level detection PDT1 arrival 4: Frequency Arrival (PAR) 5: Running at zero speed 6: Motor overload pre-alarm 7: Inverter overload pre-alarm 8: PLC cycle completed 9: Cumulative running time arrives 10: Frequency limited 11: Ready to run 12: Reserve 13: The upper limit frequency is reached 14: The lower limit frequency is reached 15: Undervoltage status output 16: Communication settings | 1 | ☆ |

Chapter 8 Function & Parameter Table

| Function code | Name | Description (setting range) | Factory Default | Change |
|---------------|------|--|-----------------|--------|
| | | 17: Timer output | | |
| | | 18: Reverse running | | |
| | | 19: Reserved | | |
| | | 20: Set length reached | | |
| | | 21: Torque limited | | |
| | | 22: Current 1 arrives | | |
| | | 23: Frequency 1 arrives | | |
| | | 24: Module temperature reached | | |
| | | 25: Dropping | | |
| | | 26: Cumulative power-on time arrives | | |
| | | 27: Timed arrival output | | |
| | | 28: The running time has arrived | | |
| | | 29: Set count value reached | | |
| | | 30: The specified count value arrives | | |
| | | 31: Motor 1, Motor 2 indication | | |
| | | 32: Brake control output | | |
| | | 33: Running at zero speed 2 | | |
| | | 34: Frequency level detection PDT2 arrival | | |
| | | 35: Zero current state | | |
| | | 36: Software current overrun | | |
| | | 37: The lower limit frequency is reached, and the output is also output when stopped | | |
| | | 38: Alarm output | | |
| | | 39: Reserved | | |
| | | 40: AI1 input overrun | | |
| | | 41: Reserved | | |
| | | 42: reserved | | |
| | | 43: Frequency reached 2 | | |
| | | 44: Current reaches 2 | | |
| | | 45: Fault output | | |

| Function code | Name | Description (setting range) | Factory Default | Change |
|---------------|-------------------------------|---|-----------------|--------|
| P6-04 | Y terminal output mode Select | 0: Pulse output (FMP) 1: Open collector switching output (FMR) | 0 | ☆ |
| P6-05 | FMR output selection | Similar to P6-01 to select the output mode of parameters | 0 | ☆ |
| P6-09 | AO1 output selection | 0: Operating frequency 1: Set frequency 2: Output current (100% corresponds to twice the rated motor current) 3: Output power (100% corresponds to 2 times the rated motor power) 4: Output voltage (100% corresponds to 1.2 times the rated voltage of the frequency converter) 5: Simulate AI1 input value 6: Reserved 7: Communication settings 8: Output torque 9: Length 10: Counting value 11: Motor speed 12: Bus voltage (0-3 times the rated voltage of the frequency converter) 13: Pulse input 14: Output current (100% corresponds to 1000.0A) 15: Output voltage (100.0% corresponds to 1000.0V) 16: Output torque (actual torque value -2 times rated to 2 times rated) | 0 | ☆ |

Chapter 8 Function & Parameter Table

| Function code | Name | Description (setting range) | Factory Default | Change |
|---------------|---|---|-----------------|--------|
| P6-11 | FMP output selection | 0: Operating frequency 1: Set frequency 2: Output current (100% corresponds to twice the rated motor current) 3: Output power (100% corresponds to 2 times the rated motor power) 4: Output voltage (100% corresponds to 1.2 times the rated voltage of the frequency converter) 5: Simulate AI1 input value 6: Reserved 7: Communication settings 8: Output torque 9: Length 10: Counting value 11: Motor speed 12: Bus voltage (0-3 times the rated voltage of the frequency converter) 13: Pulse input 14: Output current (100% corresponds to 1000.0A) 15: Output voltage (100.0% corresponds to 1000.0V) 16: Output torque (actual torque value -2 times rated to 2 times rated) | 0 | ☆ |
| P6-12 | FMP output maximum frequency | 0.01KHz ~ 100.00KHz | 50.00 | ☆ |
| P6-13 | AO1 output lower limit | -100.0% ~ P6-15 | 0.0% | ☆ |
| P6-14 | The lower limit corresponds to AO1 output | 0.00V ~ 10.00V | 0.00V | ☆ |
| P6-15 | AO1 output upper limit | P6-13 ~ 100.0% | 100.0% | ☆ |
| P6-16 | The upper limit corresponds to AO1 output | 0.00 ~ 10.00V | 10.00V | ☆ |
| P6-21 | Main relay T pick-up delay | 0.0s ~ 3600.0s | 0.0s | ☆ |

| Function code | Name | Description (setting range) | Factory Default | Change |
|---|--|---|-----------------|--------|
| P6-26 | Main relay T off delay | 0.0s ~ 3600.0s | 0.0s | ☆ |
| Group P7: Accessibility and keyboard display | | | | |
| P7-00 | Jog running frequency | 0.00Hz ~ Maximum frequency | 6.00Hz | ☆ |
| P7-01 | Jog acceleration time | 0.0s ~ 3000.0s | 10.0s | ☆ |
| P7-02 | Jog deceleration time | 0.0s ~ 3000.0s | 10.0s | ☆ |
| P7-03 | Acceleration time 2 | 0.0s ~ 3000.0s | 10.0s | ☆ |
| P7-04 | Deceleration time 2 | 0.0s ~ 3000.0s | 10.0s | ☆ |
| P7-05 | Acceleration time 3 | 0.0s ~ 3000.0s | 10.0s | ☆ |
| P7-06 | Deceleration time 3 | 0.0s ~ 3000.0s | 10.0s | ☆ |
| P7-07 | Acceleration time 4 | 0.0s ~ 3000.0s | 10.0s | ☆ |
| P7-08 | Deceleration time 4 | 0.0s ~ 3000.0s | 10.0s | ☆ |
| P7-09 | Hop Frequency 1 | 0.00Hz ~ Maximum frequency | 0.00Hz | ☆ |
| P7-10 | Hop Frequency 1 Amplitude | 0.00Hz ~ Maximum frequency | 0.00Hz | ☆ |
| P7-11 | Hop Frequency 2 | 0.00Hz ~ Maximum frequency | 0.00Hz | ☆ |
| P7-12 | Hop Frequency 2 Amplitude | 0.00Hz ~ Maximum frequency | 0.00Hz | ☆ |
| P7-15 | Forward and reverse dead time | 0.0s ~ 3000.0s | 0.0s | ☆ |
| P7-16 | Keyboard Knob Accuracy | 0: default mode 1: 0.1Hz 2: 0.5Hz 3: 1Hz 4: 2Hz 5: 4Hz 6: 5Hz 7: 8Hz 8: 10Hz 9:0.01Hz 10:0.05Hz | 2 | ☆ |
| P7-17 | The frequency is lower than the lower limit frequency processing | 0: run at the lower frequency limit 1: shutdown 2: Running at zero speed | 0 | ☆ |
| P7-18 | Sag rate | 0.0% ~ 100.0% | 0.0% | ☆ |

Chapter 8 Function & Parameter Table

| Function code | Name | Description (setting range) | Factory Default | Change |
|---------------|--|---|-----------------|--------|
| P7-19 | Delay time for frequency lower than lower limit shutdown | 0.0s ~ 600.0s | 0.0s | ☆ |
| P7-20 | Set cumulative operating time | 0h ~ 65000h | 0h | ☆ |
| P7-21 | Jog priority | 0: Invalid 1: Jog priority mode 1 2: Jog priority mode 2 1) When the user fails or the PID is lost, the jog is still valid 2) Stop mode and DC braking can be set | 1 | ☆ |
| P7-22 | Frequency detection value (PDT1 level) | 0.00Hz ~ Maximum frequency | 50.00Hz | ☆ |
| P7-23 | Frequency check hysteresis value (PDT1 hysteresis) | 0.0% ~ 100.0% | 5.0% | ☆ |
| P7-24 | Frequency arrival detection width | 0.0% ~ 100.0% | 0.0% | ☆ |
| P7-25 | Reserve | -- | 0 | ● |
| P7-26 | Fan control | 0: The fan keeps running 1: The fan runs when the inverter is running (When the temperature is higher than 40°, the fan will also run under shutdown) | 1 | ★ |
| P7-27 | STOP/RESET function | 0: Only valid in keyboard control 1: The stop or reset function is valid in all control modes | 0 | ☆ |
| P7-28 | Quick /JOG key function selection | 0: Forward jog 1: Forward and reverse switching 2: Reverse jog 3: Switch between panel and remote control 4: Panel frequency source switching (press the Quick key to change) | 0 | ★ |

| Function code | Name | Description (setting range) | Factory Default | Change |
|---------------|---------------------------|---|-----------------|--------|
| P7-29 | LED running display | 0000 ~ 0xPFPF (hexadecimal number) 0000 to 0xPFPF Bit00: Running frequency 0001 Bit01: Set frequency 0002 Bit02: Bus voltage 0004 Bit03: Output voltage 0008 Bit04: Output current 0010 Bit05: Output power 0020 Bit06: DI input status 0040 Bit07: DO output status 0080 Bit08: AI1 voltage 0100 Bit09: Reserved Bit10: PID setting value 0400 Bit11: PID feedback value 0800 Bit12: Count value 1000 Bit13: Length value 2000 Bit14: Load speed display 4000 Bit15: PLC stage 8000 | H.441F | ☆ |
| P7-30 | LED stop display | 1 ~ 0x1PPF (hexadecimal number) Bit00: Set frequency 0001 Bit01: Bus voltage 0002 Bit02: DI input status 0004 Bit03: DO output status 0008 Bit04: AI1 voltage 0010 Bit05: Reserved Bit06: PID setting value 0040 Bit07: PID feedback value 0080 Bit08: Count value 0100 Bit09: Length value 0200 Bit10: Load speed display 0400 Bit11: PLC stage 0800 Bit12: Input pulse frequency 1000 Bit13 ~ Bit15: Reserved | H.0043 | ☆ |
| P7-31 | Load speed display factor | 0.001 ~ 655.00 | 1.000 | ☆ |
| P7-32 | Radiator temperature | 12°C ~ 100°C | Measured value | ● |
| P7-33 | Cumulative power-on time | 0h ~ 65535h | Measured value | ● |

Chapter 8 Function & Parameter Table

| Function code | Name | Description (setting range) | Factory Default | Change |
|---------------|--|--|-----------------|--------|
| P7-34 | Cumulative running time | 0h ~ 65535h | Measured value | ● |
| P7-36 | Current running timing enable selection | 0: Disable 1: Enable, When the time is up, a fault is reported 2: Enable, When the time is up, a fault is not reported | 0 | ★ |
| P7-37 | Selection of timing source for the current run | 0: Digital setting P7-38 1: A1 2: Reserved | 0 | ★ |
| P7-38 | Current running time set value | 0.0min ~ 6500.0min | 0.0min | ☆ |
| P7-39 | High level timing | 0.0s ~ 6000.0s | 2.0s | ☆ |
| P7-40 | low level timing | 0.0s ~ 6000.0s | 2.0s | ☆ |
| P7-41 | Activate the protection function | 0: Invalid (start terminal command is valid and start directly) 1: Valid | 1 | ☆ |
| P7-43 | Frequency reaches detection value 1 | 0.00Hz ~ P0-14 | 50.00Hz | ☆ |
| P7-44 | Frequency detection value 1 arrival width | 0.0% ~ 100.0% | 0.0% | ☆ |
| P7-45 | Current reaches detection value 1 | 0.0% ~ 300.0% | 100.0% | ☆ |
| P7-46 | Current detection value 1 arrival width | 0.0% ~ 300.0% | 0.0% | ☆ |
| P7-49 | user password | 0 ~ 65535 | 0 | ☆ |
| P7-50 | Whether the jump frequency is valid during acceleration and deceleration | 0: invalid 1: Valid | 0 | ☆ |
| P7-51 | Set the power-on arrival time | 0h ~ 65530h | 0h | ☆ |
| P7-53 | Acceleration time 1/2 switching frequency point | 0.00Hz ~ Maximum frequency (P0-14) | 0.00Hz | ☆ |
| P7-54 | Deceleration time 1/2 switching frequency point | 0.00Hz ~ Maximum frequency (P0-14) | 0.00Hz | ☆ |

| Function code | Name | Description (setting range) | Factory Default | Change |
|---------------|---|---|-----------------|--------|
| P7-55 | Frequency detection value (PDT2 level) | 0.00Hz ~ Maximum frequency (P0-14) | 50.00Hz | ☆ |
| P7-56 | Frequency detection PDT2 hysteresis value | 0.0% ~ 100.0% | 5.0% | ☆ |
| P7-57 | Frequency reaches detection value 2 | 0.00Hz ~ Maximum frequency (P0-14) | 50.00Hz | ☆ |
| P7-58 | Frequency arrival detection 2 amplitude | 0.0% ~ 100.0% | 0.0% | ☆ |
| P7-59 | Zero current detection value | 0.0% ~ 300.0% | 10.0% | ☆ |
| P7-60 | Zero current detection delay time | 0.01s ~ 300.00s | 1.00s | ☆ |
| P7-61 | Output current amplitude detection | 20.0% ~ 400.0% | 200.0% | ☆ |
| P7-62 | Software overcurrent maximum allowable time | 0s~6500.0s | 0s | ☆ |
| P7-63 | Current reaches detection value 2 | 20.0% ~ 300.0% | 100.0% | ☆ |
| P7-64 | Current arrival detection 2 amplitude | 0.0% ~ 300.0% | 0.0% | ☆ |
| P7-65 | LED running display parameter 2 | 0x0 ~ 0x1PF Bit00: Target torque% 0001 Bit01: Output torque% 0002 Bit02: Pulse input pulse frequency (KHz) 0004 Bit03: DI5 high-speed pulse sampling linear speed (m/min) 0008 Bit04: Motor speed (rpm) 0010 Bit05: AC incoming line current (A) 0020 Bit06: Cumulative running time (h) 0040 Bit07: Current running time (min) 0080 Bit08: Cumulative power consumption (kWh) 0100 Bit09 ~ Bit15: Reserved | | |

Chapter 8 Function & Parameter Table

| Function code | Name | Description (setting range) | Factory Default | Change |
|---|---|---|-----------------|--------|
| P7-67 | AI1 input voltage lower limit | 0.00V ~ P7-68 | 2.00V | ☆ |
| P7-68 | AI1 input voltage upper limit | P7-67 ~ 11.00V | 8.00V | ☆ |
| P7-69 | Module temperature reached | 0°C ~ 90°C | 70°C | ☆ |
| P7-70 | Output power display correction factor | 0.001 ~ 3.000 | 1.000 | ☆ |
| P7-71 | Linear velocity display correction factor | Linear speed=P7-71*Number of HDI pulses sampled per second/PB-07 | 1.000 | ☆ |
| P7-72 | Cumulative power consumption (kWh) | 0 ~ 65535 | Measured value | ● |
| P7-73 | Performance software version | Performance software version number | ## | ● |
| P7-74 | Functional software version | Function software version number | ## | ● |
| P7-75 | Enhanced function parameter display selection | 0: Hide enhanced function parameter group: A0 ~ A3, B0 ~ B5 1: Display enhanced function parameter group: A0 ~ A3, B0 ~ B5 | 0 | ☆ |
| P7-76 | Motor speed display correction factor | 0.0010 ~ 3.0000 | 1.0000 | ☆ |
| Group P8: Communication parameters | | | | |
| P8-00 | Baud rate setting | 0: 300BPS 1: 600BPS 2: 1200BPS 3: 2400BPS 4: 4800BPS 5: 9600BPS 6: 19200BPS | 2 | ☆ |
| P8-01 | Data Format | 0: No parity <8,N,2> 1: Even parity <8,E,1> 2: odd parity <8,O,1> 3: No parity 1<8,N,1> | 0 | ☆ |
| P8-02 | Communication address | 0 ~ 247 (0 is the broadcast address) | 1 | ☆ |

| Function code | Name | Description (setting range) | Factory Default | Change |
|---------------------------------------|---|--|-----------------|--------|
| P8-03 | Response time | 0ms ~ 30ms | 2ms | ☆ |
| P8-04 | Communication timeout | 0ms ~ 30ms | 0.0s | ☆ |
| P8-05 | Communication format selection | 0: Standard ModbusRTU protocol 1: Non-standard ModBusRTU protocol | 0 | ☆ |
| P8-06 | Background software monitoring function | 0: Disable, default 485 communication function 1: On, the background software monitoring function, the 485 communication function cannot be used at this time | 0 | ☆ |
| Group P9: Fault and Protection | | | | |
| P9-00 | Motor overload protection selection | 0: Disable 1: Allow | 1 | ☆ |
| P9-01 | Motor overload protection gain | 0.10~10.00 | 1.00 | ☆ |
| P9-02 | Motor overload warning coefficient (%) | 50% ~ 100% | 80% | ☆ |
| P9-03 | Overvoltage Stall Protection Gain | 000 ~ 100 | 030 | ☆ |
| P9-04 | Overvoltage stall protection voltage | 200.0 ~ 1200.0V | 760.0V | ★ |
| P9-05 | VF Overcurrent Stall Protection Gain | 0 ~ 100 | 20 | ☆ |
| P9-06 | VF Overcurrent Stall Protection Current | 50% ~ 200% | 150% | ★ |
| P9-07 | VF field weakening area current stall protection factor | 50% ~ 200% | 100% | ★ |
| P9-08 | Overvoltage stall allowable rise limit value | 0.0% ~ 50.0% | 10.0% | ☆ |
| P9-11 | Fault automatic reset times | 0 ~ 20 | 0 | ☆ |
| P9-12 | Fault relay action selection during automatic fault reset | 0: no action 1: Action | 0 | ☆ |

Chapter 8 Function & Parameter Table

| Function code | Name | Description (setting range) | Factory Default | Change |
|---------------|---|--|-----------------|--------|
| P9-13 | Fault automatic reset interval time | 0.1s ~ 100.0s | 1.0s | ☆ |
| P9-14 | Input phase loss enable selection | 0: invalid 1: Valid | 1 | ☆ |
| P9-15 | Output phase loss enable selection | 0: invalid 1: Valid | 1 | ☆ |
| P9-16 | Power-on to ground short-circuit protection selection | 0: invalid 1: Valid | 1 | ☆ |
| P9-17 | Undervoltage fault automatic reset selection | 0: Manual reset is required after undervoltage fault 1: After the undervoltage fault, the fault will be reset by itself according to the bus voltage | 0 | ☆ |
| P9-18 | Overvoltage suppression mode selection | 0: invalid 1: Overvoltage suppression mode 1 2: Overvoltage suppression mode 2 | 1 | ★ |
| P9-19 | Overexcitation active state selection | 0: invalid 1: Only the deceleration process is valid 2: The constant speed and deceleration process is valid during running | 2 | ★ |
| P9-20 | Overvoltage suppression mode 2 limit value | 1.0% ~ 150.0% | 10.00% | ★ |
| P9-22 | Fault protection action 1 | 0 ~ 22202; Units place: Motor overload - Err14 0: Free parking 1: stop according to the stop mode 2: keep running Ten: reserved Hundreds place: input phase loss-Err23 Thousands place: output phase loss-Err24 Ten thousand: parameter read and write exception - Err25 | 00000 | ☆ |

| Function code | Name | Description (setting range) | Factory Default | Change |
|---------------|--|--|-----------------|--------|
| P9-23 | Fault protection action 2 | 0 ~ 22222; Ones place: Communication failure - Err27 0: Free parking 1: stop according to the stop mode 2: keep running Tens place: External fault - Err28 Hundreds place: excessive speed deviation fault - Err29 Thousands: User-defined fault 1-Err30 Ten thousand: user-defined fault 2-Err31 | 00000 | ☆ |
| P9-24 | Fault protection action 3 | 0 ~ 22222; Ones place: PID feedback lost during runtime - Err32 0: Free parking 1: stop according to the stop mode 2: keep running Tens place: load loss fault - Err34 Hundreds place: software overcurrent - Err16 Thousands place: The current continuous running time reaches -Err39 Ten thousand: the running time reaches - Err40 | 00000 | ☆ |
| P9-26 | Continue to run frequency selection in case of failure | 0: run at the current operating frequency 1: run at the set frequency 2: run at the upper limit frequency 3: Run at the lower frequency limit 4: Run at the standby frequency setting value P9-27 | 1 | ☆ |
| P9-27 | Abnormal standby frequency set | 0.0% ~ 100.0% | 100% | ☆ |
| P9-28 | Drop load protection option | 0: invalid 1: Valid | 0 | ☆ |
| P9-29 | Drop load detection level | 0.0% ~ 80.0% | 20.0% | ★ |
| P9-30 | Load drop detection time | 0.0s ~ 100.0s | 5.0s | ☆ |

Chapter 8 Function & Parameter Table

| Function code | Name | Description (setting range) | Factory Default | Change |
|-------------------------------|---|--|-----------------|--------|
| P9-31 | Excessive speed deviation detection value | 0.0% ~ 100.0% | 20.0% | ☆ |
| P9-32 | Excessive speed deviation detection time | 0.0s ~ 100.0s | 0.0s | ☆ |
| P9-33 | Overspeed detection value | 0.0% ~ 100.0% | 20.0% | ☆ |
| P9-34 | Overspeed detection time | 0.0s ~ 100.0s | 2.0s | ☆ |
| P9-35 | Motor overload protection current coefficient | 100% ~ 200% | 100% | ☆ |
| Group PA: PID function | | | | |
| PA-00 | PID setting source | 0: PID function code PA-01 1: Ai1 3: Communication given 4: PULSE given 5: Multi segment instruction given 6: Up/Down modification PA-01 (effective when P0-06=6) | 0 | ☆ |
| PA-01 | PID digital setting | 0.0 ~ 100.0% | 50.0% | ☆ |
| PA-02 | PID given change time | 0.00s ~ 650.00s | 0.00s | ☆ |
| PA-03 | PID feedback source | 0: Ai1 3: Communication given 4: PULSE given | 0 | ☆ |
| PA-04 | PID action direction | 0: Forward action 1: Reverse action | 0 | ☆ |
| PA-05 | PID setting feedback range | 0 ~ 65535 | 1000 | ☆ |
| PA-06 | Proportional gain P | 0.0 ~ 100.0 | 20.0 | ☆ |
| PA-07 | Integral time I | 0.01s ~ 10.00s | 2.00s | ☆ |
| PA-08 | Differential time D | 0.000s ~ 10.000s | 0.000s | ☆ |
| PA-09 | PID reverse cutoff frequency | 0.00 ~ Maximum frequency (P0-14) | 0.00Hz | ☆ |
| PA-10 | Deviation limit | 0.0% ~ 100.0% | 0.0% | ☆ |
| PA-11 | Differential clipping | 0.00% ~ 100.00% | 0.0% | ☆ |
| PA-12 | PID feedback filter time | 0.00 ~ 60.00s | 0.00s | ☆ |

| Function code | Name | Description (setting range) | Factory Default | Change |
|--|---|---|-----------------|--------|
| PA-13 | PID feedback loss detection value | 0.00 ~ 60.00s | 0.00s | ☆ |
| PA-14 | PID feedback loss detection time | 0.0s ~ 3600.0s | 0s | ☆ |
| PA-18 | Proportional gain P2 | 0.0 ~ 100.0 | 20.0 | ☆ |
| PA-19 | Integration time I2 | 0.01s ~ 10.00s | 2.00s | ☆ |
| PA-20 | Differential time D2 | 0.000s ~ 10.000s | 0.000s | ☆ |
| PA-21 | PID parameter switching conditions | 0: Do not switch 1: DI terminal 2: Automatically switch according to the deviation | 0 | ☆ |
| PA-22 | PID parameter switching deviation 1 | 0.0% ~ PA-23 | 20.0% | ☆ |
| PA-23 | PID parameter switching deviation 2 | PA-22 ~ 100.0% | 80.0% | ☆ |
| PA-24 | PID initial value | 0.0% ~ 100.0% | 0.0% | ☆ |
| PA-25 | PID initial value hold time | 0.00s ~ 650.00s | 0.00s | ☆ |
| PA-26 | Twice output deviation positive maximum value | 0.00% ~ 100.00% | 1.00% | ☆ |
| PA-27 | Twice output deviation reverse maximum value | 0.00% ~ 100.00% | 1.00% | ☆ |
| PA-28 | PID integral properties | Units: Integral separation 0: invalid; 1: Valid Tens place: output to the limit value, whether to stop integration 0: Continue points; 1: Stop integration | 00 | ☆ |
| PA-29 | PID shutdown operation | 0: stop and do not operate 1: Compute at stop | 0 | ☆ |
| Group Pb: Swing Frequency, Fixed Length and Count | | | | |
| Pb-00 | Swing setting method | 0: Relative to the central frequency 1: Relative to the maximum frequency | 0 | ☆ |

Chapter 8 Function & Parameter Table

| Function code | Name | Description (setting range) | Factory Default | Change |
|--|---|---|-----------------|--------|
| Pb-01 | Swing frequency amplitude | 0.0% ~ 100.0% | 0.0% | ☆ |
| Pb-02 | Jump frequency amplitude | 0.0% ~ 50.0% | 0.0% | ☆ |
| Pb-03 | Swing frequency cycle | 0.1s ~ 3000.0s | 10.0s | ☆ |
| Pb-04 | Triangular wave rising time coefficient | 0.1% ~ 100.0% | 50.0% | ☆ |
| Pb-05 | Set length | 0m ~ 65535m | 1000m | ☆ |
| Pb-06 | Actual length | 0m ~ 65535m | 0m | ☆ |
| Pb-07 | Number of pulses per meter | 0.1 ~ 6553.5 | 100.0 | ☆ |
| Pb-08 | Set count value | 1 ~ 65535 | 1000 | ☆ |
| Pb-09 | Designated count value | 1 ~ 65535 | 1000 | ☆ |
| Group PC: Multi-segment instruction and simple PLC function | | | | |
| PC-00 | Multi-speed 0 | -100.0% ~ 100.0% | 0.0% | ☆ |
| PC-01 | Multi-speed 1 | -100.0% ~ 100.0% | 0.0% | ☆ |
| PC-02 | Multi-speed 2 | -100.0% ~ 100.0% | 0.0% | ☆ |
| PC-03 | Multi-speed 3 | -100.0% ~ 100.0% | 0.0% | ☆ |
| PC-04 | Multi-speed 4 | -100.0% ~ 100.0% | 0.0% | ☆ |
| PC-05 | Multi-speed 5 | -100.0% ~ 100.0% | 0.0% | ☆ |
| PC-06 | Multi-speed 6 | -100.0% ~ 100.0% | 0.0% | ☆ |
| PC-07 | Multi-speed 7 | -100.0% ~ 100.0% | 0.0% | ☆ |
| PC-08 | Multi-speed 8 | -100.0% ~ 100.0% | 0.0% | ☆ |
| PC-09 | Multi-speed 9 | -100.0% ~ 100.0% | 0.0% | ☆ |
| PC-10 | Multi-speed 10 | -100.0% ~ 100.0% | 0.0% | ☆ |
| PC-11 | Multi-speed 11 | -100.0% ~ 100.0% | 0.0% | ☆ |
| PC-12 | Multi-speed 12 | -100.0% ~ 100.0% | 0.0% | ☆ |
| PC-13 | Multi-speed 13 | -100.0% ~ 100.0% | 0.0% | ☆ |
| PC-14 | Multi-speed 14 | -100.0% ~ 100.0% | 0.0% | ☆ |
| PC-15 | Multi-speed 15 | -100.0% ~ 100.0% | 0.0% | ☆ |
| PC-16 | PLC operation mode | 0: Stop at the end of a single operation 1: Hold the final value for a single run 2: keep looping | 0 | ☆ |

| Function code | Name | Description (setting range) | Factory Default | Change |
|---------------|--|--|-----------------|--------|
| PC-17 | PLC power-down memory selection | 0: No memory when power off and no memory when stopped 1: Memory when power off and no memory when stopped 2: No memory when power off and memory when shut down 3: Power-down memory and shutdown memory | 0 | ☆ |
| PC-18 | Running time of simple PLC multi-speed 0 | 0.0s(h) ~ 6500.0s(h) | 0.0s(h) | ☆ |
| PC-19 | Acceleration/deceleration time of simple PLC multi-speed 0 | 0 ~ 3 | 0 | ☆ |
| PC-20 | Running time of simple PLC multi-speed 1 | 0.0s(h) ~ 6500.0s(h) | 0.0s(h) | ☆ |
| PC-21 | Acceleration/deceleration time of simple PLC multi-speed 1 | 0 ~ 3 | 0 | ☆ |
| PC-22 | Running time of simple PLC multi-speed 2 | 0.0s(h) ~ 6500.0s(h) | 0.0s(h) | ☆ |
| PC-23 | Acceleration/deceleration time of simple PLC multi-speed 2 | 0 ~ 3 | 0 | ☆ |
| PC-24 | Running time of simple PLC multi-speed 3 | 0.0s(h) ~ 6500.0s(h) | 0.0s(h) | ☆ |
| PC-25 | Acceleration/deceleration time of simple PLC multi-speed 3 | 0 ~ 3 | 0 | ☆ |
| PC-26 | Running time of simple PLC multi-speed 4 | 0.0s(h) ~ 6500.0s(h) | 0.0s(h) | ☆ |
| PC-27 | Acceleration/deceleration time of simple PLC multi-speed 4 | 0 ~ 3 | 0 | ☆ |
| PC-28 | Running time of simple PLC multi-speed 5 | 0.0s(h) ~ 6500.0s(h) | 0.0s(h) | ☆ |

Chapter 8 Function & Parameter Table

| Function code | Name | Description (setting range) | Factory Default | Change |
|---------------|---|-----------------------------|-----------------|--------|
| PC-29 | Acceleration/deceleration time of simple PLC multi-speed 5 | 0 ~ 3 | 0 | ☆ |
| PC-30 | Running time of simple PLC multi-speed 6 | 0.0s(h) ~ 6500.0s(h) | 0.0s(h) | ☆ |
| PC-31 | Acceleration/deceleration time of simple PLC multi-speed 6 | 0 ~ 3 | 0 | ☆ |
| PC-32 | Running time of simple PLC multi-speed 7 | 0.0s(h) ~ 6500.0s(h) | 0.0s(h) | ☆ |
| PC-33 | Acceleration/deceleration time of simple PLC multi-speed 7 | 0 ~ 3 | 0 | ☆ |
| PC-34 | Running time of simple PLC multi-speed 8 | 0.0s(h) ~ 6500.0s(h) | 0.0s(h) | ☆ |
| PC-35 | Acceleration/deceleration time of simple PLC multi-speed 8 | 0 ~ 3 | 0 | ☆ |
| PC-36 | Running time of simple PLC multi-speed 9 | 0.0s(h) ~ 6500.0s(h) | 0.0s(h) | ☆ |
| PC-37 | Acceleration/deceleration time of simple PLC multi-speed 9 | 0 ~ 3 | 0 | ☆ |
| PC-38 | Running time of simple PLC multi-speed 10 | 0.0s(h) ~ 6500.0s(h) | 0.0s(h) | ☆ |
| PC-39 | Acceleration/deceleration time of simple PLC multi-speed 10 | 0 ~ 3 | 0 | ☆ |
| PC-40 | Running time of simple PLC multi-speed 11 | 0.0s(h) ~ 6500.0s(h) | 0.0s(h) | ☆ |
| PC-41 | Acceleration/deceleration time of simple PLC multi-speed 11 | 0 ~ 3 | 0 | ☆ |
| PC-42 | Running time of simple PLC multi-speed 12 | 0.0s(h) ~ 6500.0s(h) | 0.0s(h) | ☆ |

| Function code | Name | Description (setting range) | Factory Default | Change |
|---------------|---|--|-----------------|--------|
| PC-43 | Acceleration/deceleration time of simple PLC multi-speed 12 | 0 ~ 3 | 0 | ☆ |
| PC-44 | Acceleration/deceleration time of simple PLC multi-speed 13 | 0.0 ~ 6500.0 | 0 | ☆ |
| PC-45 | Running time of simple PLC multi-speed 14 | 0~3 (respectively representing acceleration and deceleration time 1~4) | 0.0s(h) | ☆ |
| PC-46 | Acceleration/deceleration time of simple PLC multi-speed 14 | 0.0 ~ 6500.0 | 0 | ☆ |
| PC-47 | Running time of simple PLC multi-speed 15 | 0~3 (respectively representing acceleration and deceleration time 1~4) | 0.0s(h) | ☆ |
| PC-48 | Acceleration/deceleration time of simple PLC multi-speed 15 | 0.0 ~ 6500.0 | 0 | ☆ |
| PC-49 | Running time of simple PLC multi-speed 15 | 0~3 (respectively representing acceleration and deceleration time 1~4) | 0.0s(h) | ☆ |
| PC-50 | Time unit of multi-speed | 0: s (second) 1:h (hour) | 0 | ☆ |
| PC-51 | Multi-speed priority mode selection | 0: Multi-speed does not have priority 1: Multi-speed priority | 1 | ☆ |
| PC-52 | Multi-speed priority acceleration and deceleration time selection | 0: Acceleration and deceleration time 1 1: Acceleration and deceleration time 2 2: Acceleration and deceleration time 3 3: Acceleration and deceleration time 4 | 0 | ☆ |
| PC-53 | Multi-speed PC-00 ~ PC-15 unit selection | 0: % 1: Hz | 0 | ☆ |

Chapter 8 Function & Parameter Table

| Function code | Name | Description (setting range) | Factory Default | Change |
|---------------------------------|---|---|-----------------|--------|
| PC-55 | Multi-segment instruction 0 given mode | 0: Function code PC-00 given 1: Ai1 2: Reserved 3: PULSE pulse 4: PID 5: Pre set frequency setting (P0-11), UP/DOWN can be modified | 0 | ☆ |
| Group PD: Torque control | | | | |
| PD-00 | Torque command source selection | 0: Digital setting (PD-01) 1: Ai1 2: Reserved 3: Communication given 4: PULSE pulse frequency setting 5: Reserved (Options 1, 3, and 4 correspond to PD-01 at full scale) | 0 | ★ |
| PD-01 | Torque digital given | -200.0% ~ 200.0% | 150.0% | ☆ |
| PD-03 | Torque control positive direction maximum frequency | 0.00Hz ~ Maximum frequency (P0-14) | 50.00Hz | ☆ |
| PD-04 | Torque control reverse direction maximum frequency | 0.00Hz ~ Maximum frequency (P0-14) | 50.00Hz | ☆ |
| PD-06 | Torque command filter time | 0.00s ~ 10.00s | 0.00s | ☆ |
| PD-07 | Torque mode frequency acceleration time | 0.0s ~ 1000.0s | 10.0s | ☆ |
| PD-08 | Torque mode frequency deceleration time | 0.0s ~ 1000.0s | 10.0s | ☆ |
| PD-10 | Speed/torque mode selection | 0: Speed mode 1: Torque mode | 0 | ★ |

| Function code | Name | Description (setting range) | Factory Default | Change |
|---|--|----------------------------------|-----------------|--------|
| Group PE: AI multi-point curve setting | | | | |
| PE-00 | Curve 1 minimum input | -10.00V ~ PE-02 | 0.00V | ☆ |
| PE-01 | Curve 1 minimum input corresponding setting | -100.0% ~ 100.0% | 0.0% | ☆ |
| PE-02 | Curve 1 Knee 1 Input | PE-00 ~ PE-04 | 3.00V | ☆ |
| PE-03 | Curve 1 inflection point 1 input corresponding setting | -100.0% ~ 100.0% | 30.0% | ☆ |
| PE-04 | Curve 1 Knee 2 Input | PE-02 ~ PE-06 | 6.00V | ☆ |
| PE-05 | Curve 1 inflection point 2 input corresponding setting | -100.0% ~ 100.0% | 60.0% | ☆ |
| PE-06 | Curve 1 maximum input | PE-04 ~ 10.00 | 10.00V | ☆ |
| PE-07 | Curve 1 maximum input corresponding setting | -100.0% ~ 100.0% | 100.0% | ☆ |
| PE-08 | Curve 2 minimum input | -10.00 ~ PE-10 | 0.00V | ☆ |
| PE-09 | Curve 2 minimum input corresponding setting | -100.0% ~ 100.0% | 0.0% | ☆ |
| PE-10 | Curve 2 Knee 1 Input | PE-08 ~ PE-12 | 3.00V | ☆ |
| PE-11 | Curve 2 inflection point 1 input corresponding setting | -100.0% ~ 100.0% | 30.0% | ☆ |
| PE-12 | Curve 2 Knee 2 Input | PE-10 ~ PE-14 | 6.00V | ☆ |
| PE-13 | Curve 2 inflection point 2 input corresponding setting | -100.0% ~ 100.0% | 60.0% | ☆ |
| PE-14 | Curve 2 maximum input | PE-12 ~ 10.00V | 10.00V | ☆ |
| PE-15 | Curve 2 maximum input corresponding setting | -100.0% ~ 100.0% | 100.0% | ☆ |
| PE-24 | AI1 set jump point | -100.0% ~ 100.0% | 0.0% | ☆ |
| PE-25 | AI1 sets the jump range | 0.0% ~ 100.0% | 0.5% | ☆ |
| Group PF: Manufacturer parameters | | | | |
| PF.00 | Factory password | 0 ~ 65535 | ***** | ☆ |
| Group A0: Second motor parameter setting | | | | |
| A0-00 | Motor selection | 1: Motor No. 1 2: Motor No. 2 | 1 | ★ |

Chapter 8 Function & Parameter Table

| Function code | Name | Description (setting range) | Factory Default | Change |
|--|---|--|---------------------|--------|
| A0-01 | The second motor control mode | 1: Open loop vector control (speed sensorless vector) 2: VF Control | 2 | ★ |
| A0-02 | Second motor acceleration and deceleration time selection | 0: Consistent with the first motor 1: Acceleration and deceleration time 1 2: Acceleration and deceleration time 2 3: Acceleration and deceleration time 3 4: Acceleration and deceleration time 4 | 0 | ☆ |
| Group A1: Second Motor Parameters | | | | |
| A1-00 | Motor parameter tuning | 0: No function 1: Static tuning 2: Dynamic full tuning | 0 | ★ |
| A1-01 | Motor 2 rated power | 0.1Kw ~ 1000.0Kw | Model is determined | ★ |
| A1-02 | Motor 2 rated voltage | 1V ~ 1500V | 380V | ★ |
| A1-03 | Motor 2 Number of motor poles | 2 to 64 | Model is determined | ● |
| A1-04 | Motor 2 rated current | 0.01A ~ 600.00A(Motor rated power<=30.0KW) 0.1A ~ 6000.0A(Motor rated power>30.0KW) | A1-01 OK | ★ |
| A1-05 | Motor 2 rated frequency | 0.01Hz ~ Maximum frequency (P0-14) | 50.00Hz | ★ |
| A1-06 | Motor 2 rated speed | 1rpm ~ 65535rpm | A1-01 OK | ★ |
| A1-07 | Motor 2 no-load current | 0.01A ~ A1-04 (Motor rated power<=30.0KW) 0.1A ~ A1-04 (Motor rated power>30.0KW) | A1-01 OK | ★ |
| A1-08 | Motor 2 stator resistance | 0.001ohm ~ 65.535ohm | Model is determined | ★ |

| Function code | Name | Description (setting range) | Factory Default | Change |
|---|---|---|---------------------|--------|
| A1-09 | Motor 2 rotor resistance | 0.001ohm ~ 65.535ohm | Model is determined | ★ |
| A1-10 | Motor 2 mutual inductance | 0.1mH ~ 6553.5mH | Model is determined | ★ |
| A1-11 | Motor 2 leakage inductance | 0.01mH ~ 655.35mH | Model is determined | ★ |
| A1-12 | Acceleration at Dynamic Full Tuning | 1.0s ~ 6000.0s | 10.0s | ☆ |
| A1-13 | Deceleration at dynamic full tuning | 1.0s ~ 6000.0s | 10.0s | ☆ |
| Group A2: Second motor VF parameter setting | | | | |
| A2-00 | Torque boost | 0.0% ~ 30.0% | 0.0% | ☆ |
| A2-01 | Oscillation suppression gain | 0 ~ 100 | Model is determined | ☆ |
| Group A3: Second motor vector control parameters | | | | |
| A3-00 | Switching frequency P1 | 0.00Hz ~ A3-02 | 5.00Hz | ☆ |
| A3-02 | Switching frequency P2 | A3-00 ~ P0-14 | 10.00Hz | ☆ |
| A3-04 | Low frequency speed proportional gain | 0.1 ~ 10.0 | 4.0 | ☆ |
| A3-05 | Low frequency speed integration time | 0.01s ~ 10.00s | 0.50s | ☆ |
| A3-06 | High frequency speed proportional gain | 0.1 ~ 10.0 | 2.0 | ☆ |
| A3-07 | High frequency speed integration time | 0.01s ~ 10.00s | 1.00s | ☆ |
| A3-08 | Speed loop integral attribute selection | 0: Points take effect 1: Integral separation | 0 | ★ |
| A3-11 | Torque current regulator Kp | 0 ~ 30000 | 2000 | ☆ |
| A3-12 | Torque current regulator Ki | 0 ~ 30000 | 1300 | ☆ |
| A3-13 | Excitation current regulator Kp | 0 ~ 30000 | 2000 | ☆ |
| A3-14 | Excitation current regulator Ki | 0 ~ 30000 | 1300 | ☆ |
| A3-15 | Flux Brake Gain | 0~200 | 0 | ☆ |

Chapter 8 Function & Parameter Table

| Function code | Name | Description (setting range) | Factory Default | Change |
|------------------------------------|--|---|-----------------|--------|
| A3-16 | Field weakening torque correction factor | 50%~200% | 100% | ☆ |
| A3-17 | Slip Compensation Coefficient | 50% ~ 200% | 100% | ☆ |
| A3-18 | Speed loop feedback filter time constant | 0.000s ~ 1.000s | 0.015s | ☆ |
| A3-19 | Speed loop output filter time constant | 0.000s ~ 1.000s | 0.000s | ☆ |
| A3-20 | Electric torque upper limit source | 0: P3-21 1: A11 (analog range corresponds to P3-21) 2: Reserved 3: Communication given 4: PLUSE Given | 0 | ☆ |
| A3-21 | Electric torque upper limit | 0.0% ~ 200.0% | 150.0% | ☆ |
| A3-22 | Braking torque upper limit source | 0: P3-23 1: A11 (analog range corresponds to P3-23) 3: Communication given 4: PLUSE Given | 0 | ☆ |
| A3-23 | Braking torque upper limit | 0.0% ~ 200.0% | 150% | ☆ |
| Group B0: System parameters | | | | |
| B0-00 | Function code read-only selection | 0: Invalid 1: Read only | 0 | ☆ |
| B0-01 | LCD top menu display/LED second line display | 0: Output current 1: Motor speed 2: Load speed 3: Output voltage 4: PID given 5: PID feedback | 0 | ☆ |
| B0-02 | LCD language selection | 0: Chinese 1: English | 0 | ● |
| B0-03 | LED menu toggle selection | 0: Disable 1: enable | 0 | ☆ |

| Function code | Name | Description (setting range) | Factory Default | Change |
|---|--|---|-----------------|--------|
| B0-04 | Vector operating frequency display selection | 0: real-time frequency 1: set frequency | 0 | ☆ |
| B0-05 | Display selection during UP/Down adjustment | 0: Display the set value 1: Display the current variable value | 0 | ☆ |
| Group B1: User function code customization | | | | |
| B1-00 | Clear custom function code selection | 0: invalid 1: Valid | 0 | ☆ |
| B1-01 | Custom function code 1 | uP0-00 ~ uU1-xx | uP0-03 | ☆ |
| B1-02 | Custom function code 2 | uP0-00 ~ uU1-xx | uP0-04 | ☆ |
| B1-03 | Custom function code 3 | uP0-00 ~ uU1-xx | uP0-06 | ☆ |
| B1-04 | Custom function code 4 | uP0-00 ~ uU1-xx | uP0-23 | ☆ |
| B1-05 | Custom function code 5 | uP0-00 ~ uU1-xx | uP0-24 | ☆ |
| B1-06 | Custom function code 6 | uP0-00 ~ uU1-xx | uP4-00 | ☆ |
| B1-07 | Custom function code 7 | uP0-00 ~ uU1-xx | uP4-01 | ☆ |
| B1-08 | Custom function code 8 | uP0-00 ~ uU1-xx | uP4-02 | ☆ |
| B1-09 | Custom function code 9 | uP0-00 ~ uU1-xx | uP4-04 | ☆ |
| B1-10 | Custom function code 10 | uP0-00 ~ uU1-xx | uP4-05 | ☆ |
| B1-11 | Custom function code 11 | uP0-00 ~ uU1-xx | uP4-06 | ☆ |
| B1-12 | Custom function code 12 | uP0-00 ~ uU1-xx | uP4-12 | ☆ |
| B1-13 | Custom function code 13 | uP0-00 ~ uU1-xx | uP4-13 | ☆ |
| B1-14 | Custom function code 14 | uP0-00 ~ uU1-xx | uP5-00 | ☆ |
| B1-15 | Custom function code 15 | uP0-00 ~ uU1-xx | uP5-01 | ☆ |
| B1-16 | Custom function code 16 | uP0-00 ~ uU1-xx | uP5-02 | ☆ |
| B1-17 | Custom function code 17 | uP0-00 ~ uU1-xx | uP6-00 | ☆ |
| B1-18 | Custom function code 18 | uP0-00 ~ uU1-xx | uP6-01 | ☆ |
| B1-19 | Custom function code 19 | uP0-00 ~ uU1-xx | uP0-00 | ☆ |
| B1-20 | Custom function code 20 | uP0-00 ~ uU1-xx | uP0-00 | ☆ |

Chapter 8 Function & Parameter Table

| Function code | Name | Description (setting range) | Factory Default | Change |
|--|--|---|------------------|--------|
| B1-21 | Custom function code 21 | uP0-00 ~ uU1-xx | uP0-00 | ☆ |
| B1-22 | Custom function code 22 | uP0-00 ~ uU1-xx | uP0-00 | ☆ |
| B1-23 | Custom function code 23 | uP0-00 ~ uU1-xx | uP0-00 | ☆ |
| B1-24 | Custom function code 24 | uP0-00 ~ uU1-xx | uP0-00 | ☆ |
| B1-25 | Custom function code 25 | uP0-00 ~ uU1-xx | uP0-00 | ☆ |
| B1-26 | Custom function code 26 | uP0-00 ~ uU1-xx | uP0-00 | ☆ |
| B1-27 | Custom function code 27 | uP0-00 ~ uU1-xx | uP0-00 | ☆ |
| B1-28 | Custom function code 28 | uP0-00 ~ uU1-xx | uP0-00 | ☆ |
| B1-29 | Custom function code 29 | uP0-00 ~ uU1-xx | uP0-00 | ☆ |
| B1-30 | Custom function code 30 | uP0-00 ~ uU1-xx | uP0-00 | ☆ |
| B1-31 | Custom function code 31 | uP0-00 ~ uU1-xx | uP0-00 | ☆ |
| Group B2: Optimize control parameters | | | | |
| B2-00 | Dead Time Compensation Enable Selection | 0: No compensation 1: Compensation | 1 | ☆ |
| B2-01 | PWM method | 0: Asynchronous modulation 1: Synchronous modulation | 0 | ☆ |
| B2-02 | PWM seven-segment/five-segment selection | 0: 7 segments in the whole process 1: Seven-segment/five-segment automatic switching | 0 | ☆ |
| B2-03 | CBC current limit enable selection | 0: Disable 1: enable | 1 | ☆ |
| B2-04 | Braking point | 330.0V ~ 1200.0V | 360.0V 690.0V | ☆ |
| B2-05 | Undervoltage point | 150.0V ~ 500.0V | 200.0V 350.0V | ☆ |
| B2-06 | Random PWM depth setting | 0 ~ 6 | 0 | ☆ |

| Function code | Name | Description (setting range) | Factory Default | Change |
|--|---|--|-----------------|--------|
| B2-07 | 0Hz operating mode selection | 0: No current output; 1: Normal operation; 2: Output with stop DC braking current P1-16; | 0 | ☆ |
| B2-08 | Low frequency carrier limitation mode selection | 0: limit mode 0 1: Restricted Mode 1 2: Unlimited (the carrier of all frequency bands is the same) | 0 | ☆ |
| Group B3: AIAO correction parameters | | | | |
| B3-00 | AI1 shows voltage 1 | -9.999V ~ 10.000V | 3.000V | ☆ |
| B3-01 | AI1 measured voltage 1 | -9.999V ~ 10.000V | 3.000V | ☆ |
| B3-02 | AI1 shows voltage 2 | -9.999V ~ 10.000V | 8.000V | ☆ |
| B3-03 | AI1 measured voltage 2 | -9.999V ~ 10.000V | 8.000V | ☆ |
| B3-12 | AO1 target voltage 1 | -9.999V ~ 10.000V | 3.000V | ☆ |
| B3-13 | AO1 measured voltage 1 | -9.999V ~ 10.000V | 3.000V | ☆ |
| B3-14 | AO1 target voltage 2 | -9.999V ~ 10.000V | 8.000V | ☆ |
| B3-15 | AO1 measured voltage 2 | -9.999V ~ 10.000V | 8.000V | ☆ |
| Group B4: Master-slave control parameters | | | | |
| B4-00 | Master-slave control enable selection: | 0: Disable 1: Enable | 0 | ★ |
| B4-01 | Master-slave selection: | 0: Host 1: Slave | 0 | ★ |
| B4-02 | Host sending frequency selection: | 0: Running frequency 1: Target frequency | 0 | ★ |
| B4-03 | Slave follow master command source selection | 0: Do not follow 1: Follow | 0 | ★ |
| B4-04 | Slave receive frequency coefficient | 0.00% ~ 600.00% | 100.00% | ☆ |
| B4-05 | Slave receives torque coefficient | -10.00 ~ 10.00 | 1.00 | ☆ |
| B4-06 | Slave receives torque bias | -50.00% ~ 50.00% | 0.00% | ☆ |
| B4-07 | Frequency deviation threshold | 0.20% ~ 10.00% | 0.50% | ☆ |

Chapter 8 Function & Parameter Table

| Function code | Name | Description (setting range) | Factory Default | Change |
|---|--|--|-----------------|--------|
| B4-08 | Master-slave communication drop detection time | 0.00s ~ 10.0s | 0.1s | ☆ |
| Group B5: Brake function parameters | | | | |
| B5-00 | Brake control enable selection: | 0: Disable 1: Enable | 0 | ★ |
| B5-01 | brake release frequency | 0.00Hz ~ 20.00Hz | 2.50Hz | ★ |
| B5-02 | Brake release frequency maintenance time | 0.0s ~ 20.0s | 1.0s | ★ |
| B5-03 | Current limit value during holding brake | 50.0% ~ 200.0% | 120.0% | ★ |
| B5-04 | Brake pull-in frequency | 0.00Hz ~ 20.00Hz | 1.50Hz | ★ |
| B5-05 | Brake pull-in delay time | 0.0s ~ 20.0s | 0.0s | ★ |
| B5-06 | Holding time of brake pull-in frequency | 0.0s ~ 20.0s | 1.0s | ★ |
| Group B6: Sleep wakeup function parameters | | | | |
| B6-00 | Hibernate selection | 0: The sleep function is invalid 1: Digital input terminal DI controls sleep function 2: Sleep function controlled by PID set value and feedback value 3: Control sleep function based on operating frequency | 0 | ☆ |
| B6-01 | Sleep frequency | 0.00Hz ~ P0-14 | 0.00Hz | ☆ |
| B6-02 | Sleep delay | 0.0s ~ 3600.0s | 20.0s | ☆ |
| B6-03 | Wake-up difference | 0.0% ~ 100.0% When B6-00=3, the unit becomes Hz | 10.0% | ☆ |
| B6-04 | Wake up delay | 0.0s ~ 3600.0s | 0.5s | ☆ |
| B6-05 | Sleep delay frequency output selection | 0: PID automatic adjustment 1: Sleep frequency B6-01 | 0 | ☆ |

| Function code | Name | Description (setting range) | Smallest unit | Change |
|---|----------------------------------|---|---------------|--------|
| Group U0: Fault logging parameters | | | | |
| U0-00 | Last failure type | 00: No fault Err01: Inverter module protection Err04: Overcurrent during acceleration Err05: Overcurrent during deceleration Err06: Overcurrent during constant speed operation Err08: Overvoltage during acceleration Err09: Overvoltage during deceleration Err10: Overvoltage during constant speed operation Err12: Undervoltage fault | 1 | ● |
| U0-01 | Last failure type | Err13: Drive overload fault Err14: Motor overload fault Err15: Drive overheated Err17: Current detection failure Err20: Short circuit fault to ground Err23: Input phase loss fault Err24: output phase loss fault Err25: Eeprom operation failure Err27: Communication failure Err28: External fault Err29: The speed deviation is too large | 1 | ● |
| U0-02 | Types of first and second faults | Err30: User-defined fault 1 Err31: User-defined fault 2 Err33: Fast current limiting Err34: load drop fault Err32: PID feedback lost during runtime Err35: Input power failure Err37: parameter storage exception Err39: The running time has arrived Err40: Cumulative running time reached Err42: Switch the motor during operation Err46: Master-slave control communication dropped | 1 | ● |

Chapter 8 Function & Parameter Table

| Function code | Name | Smallest unit | Change |
|---------------|---|---------------|--------|
| U0-03 | Frequency of last failure | 0.01Hz | ● |
| U0-04 | Current at last fault | 0.01A | ● |
| U0-05 | Bus voltage at last fault | 0.1V | ● |
| U0-06 | Input terminal status at the last fault | 1 | ● |
| U0-07 | Output terminal status at the last fault | 1 | ● |
| U0-08 | Last fault inverter status | 1 | ● |
| U0-09 | Running time at the last fault (starting time after power-on, minutes) | 1min | ● |
| U0-10 | Running time at the last failure (time from running time, minutes) | 1min | ● |
| U0-13 | Frequency at last failure | 0.01Hz | ● |
| U0-14 | Current at previous fault | 0.01A | ● |
| U0-15 | Bus voltage at previous fault | 0.1V | ● |
| U0-16 | Input terminal at the previous fault | 1 | ● |
| U0-17 | Output terminal when the previous fault | 1 | ● |
| U0-18 | Last fault inverter status | 1 | ● |
| U0-19 | The running time of the previous fault (start timing after power-on, minutes) | 1min | ● |
| U0-20 | Time of last failure (timed from runtime, minutes) | 1min | ● |
| U0-21 | reserved variable | -- | ● |
| U0-22 | reserved variable | - | ● |
| U0-23 | The frequency of the first and second faults | 0.01Hz | ● |
| U0-24 | Current at the first and second faults | 0.01A | ● |
| U0-25 | Bus voltage at the first and second faults | 0.1V | ● |
| U0-26 | Input terminal for the first and second faults | 1 | ● |
| U0-27 | Output terminal when the first and second faults | 1 | ● |
| U0-28 | Inverter status of previous and second faults | 1 | ● |

| Function code | Name | Smallest unit | Change |
|--|--|---------------|--------|
| U0-29 | The running time of the first and second faults (start timing after power-on, minutes) | 1min | ● |
| U0-30 | The time of the first and second failures (timed from the running time, minutes) | 1min | ● |
| Group U1: Application Monitoring Parameters | | | |
| U1-00 | Operating frequency (Hz) | 0.01Hz | ● |
| U1-01 | Set frequency (Hz) | 0.01Hz | ● |
| U1-02 | Bus voltage (V) | 0.1V | ● |
| U1-03 | Output voltage (V) | 1V | ● |
| U1-04 | Output current (A) | 0.1A | ● |
| U1-05 | Output power (Kw) | 0.1kW | ● |
| U1-06 | DI input status, hexadecimal number | 1 | ● |
| U1-07 | DO output status, hexadecimal number | 1 | ● |
| U1-08 | Voltage after AI1 correction | 0.01V | ● |
| U1-10 | PID set value, PID set value (percentage)*PA-05 | 1 | ● |
| U1-11 | PID feedback, PID feedback value (percentage)*PA-05 | 1 | ● |
| U1-12 | Count value | 1 | ● |
| U1-13 | Length value | 1 | ● |
| U1-14 | Motor speed | rpm | ● |
| U1-15 | PLC stage, the current segment during multi-speed operation | 1 | ● |
| U1-16 | PULSE pulse input frequency | 0.01kHz | ● |
| U1-17 | Feedback speed, the actual operating frequency of the motor | 0.1Hz | ● |
| U1-18 | P7-38 Remaining time of timing time | 0.1Min | ● |
| U1-19 | AI1 voltage before correction | 0.001V | ● |
| U1-21 | DI5 high-speed pulse sampling line speed, refer to P7-71 for use | 1m/min | ● |
| U1-22 | Load speed display (set load speed when stopped), refer to P7-31 for use | customize | ● |
| U1-23 | The power-on time | 1Min | ● |

Chapter 8 Function & Parameter Table

| Function code | Name | Smallest unit | Change |
|---------------|--|---------------|--------|
| U1-24 | This running time | 0.1Min | ● |
| U1-25 | PULSE pulse input frequency, different from U1-16 only in unit | 1Hz | ● |
| U1-26 | Communication setting frequency value | 0.01% | ● |
| U1-27 | Main frequency display | 0.01Hz | ● |
| U1-28 | Auxiliary frequency display | 0.01Hz | ● |
| U1-29 | Target torque, take the motor rated torque as 100% | 0.1% | ● |
| U1-30 | Output torque, take the motor rated torque as 100% | 0.1% | ● |
| U1-31 | Output torque, with the rated current of the inverter as 100% | 0.1% | ● |
| U1-32 | Torque upper limit, the rated current of the inverter is 100% | 0.1% | ● |
| U1-33 | VF separation target voltage | 1V | ● |
| U1-34 | VF split output voltage | 1V | ● |
| U1-36 | Motor serial number currently in use | 1 | ● |
| U1-37 | AO1 target voltage | 0.01V | ● |
| U1-38 | AO2 target voltage | 0.01V | ● |
| U1-39 | Inverter running status, 0: Stop, 1: Forward, 2: Reverse, 3: Fault | 1 | ● |
| U1-40 | Inverter current fault | 1 | ● |
| U1-41 | Agent time remaining | 1h | ● |
| U1-42 | AC incoming line current | 0.1A | ● |
| U1-43 | PLC current phase remaining time | 0.1 | ● |
| U1-47 | Cumulative running time 1 (cumulative running time = U1-47 + U1-48) | 1h | ● |
| U1-48 | Cumulative running time 2 (cumulative running time = U1-47 + U1-48) | 1min | ● |

WARRANTY

- ❶ The company solemnly promises that users will enjoy the following warranty services from the date of purchase of products from our company (hereinafter referred to as the manufacturer).
- ❷ Since the product was purchased by the user from the manufacturer, enjoy the following three guarantee services:
 - ⌘ Return, replacement and repair within 30 days of delivery:
 - ⌘ Replacement and repair within 90 days of delivery:
 - ⌘ Repair within 18 months of delivery:
 - ⌘ Except when exporting abroad.
- ❸ This product enjoys lifetime paid service from the date of purchase by the user from the manufacturer.
- ❹ Disclaimer: Product failure caused by the following reasons is not covered by the manufacturer's free warranty service:
 - ⌘ Failure caused by the user's use and operation in accordance with the requirements of the «Instruction Manual»:
 - ⌘ Failure caused by the user to repair or modify the product without communicating with the manufacturer:
 - ⌘ Failure caused by abnormal aging of the product due to poor user environment:
 - ⌘ Failures caused by natural disasters such as earthquakes, fires, floods or abnormal voltages:
 - ⌘ Damage to the product during transportation (the transportation method is specified by the customer, and the company assists in handling the cargo consignment procedures)
- ❺ Under the following conditions, manufacturers have the right not to provide warranty services:
 - ⌘ When the manufacturer's product logo, trademark, nameplate, etc. are damaged or unrecognizable:
 - ⌘ When the user fails to pay the purchase price in accordance with the signed contract:
 - ⌘ The user intentionally conceals the manufacturer's after-sales service unit when the product is installed, wired, operated, maintained or otherwise improperly used
- ❻ For the service of return, replacement and repair, the company must return or return to the company, and it can only be returned or repaired after confirming the responsibility vested.

WARRANTY CARD

| User information | | | |
|------------------------------|--|----------------|--|
| User name | | | |
| User address | | | |
| Postal code | | Contact person | |
| Tel | | Fax | |
| Machine type | | Machine code | |
| Agent / Reseller Information | | | |
| Supplier | | | |
| Contact | | | |
| Tel | | Delivery date | |

CERTIFICATE OF QUALITY

QC test: _____

This product has been tested by our company's quality department, and its performance meets the standards, passes the inspection, and is approved to leave the factory.

Energy efficient , beautiful environment



SHENZHEN K-EASY AUTOMATION CO.,LIMITED

📍 Add: Wisdom Lmgyu, baishixia community, Fuyong street, Bao 'an District, Shenzhen, China

☎ Tel: +86-0755-27850411

📞 Wechat/Whats App:+86-19924552818

✉ E-mail: Sales@keasyautomation.com

🌐 <http://www.keasyautomation.com>

Design date: January 8, 2024

Version
1.0